

Parker Fly Fretboard to Neck Jig

Julia DeLo and Niall Lynch

The purpose of the fretboard to neck jig is to properly affix the carbon fiber fretboard to the guitar neck. The definition of a jig “is a type of custom-made tool used to control the location and/or motion of parts or other tools.” This specific jig ensures that pressure is evenly distributed along the fretboard while avoiding pressing down on the frets. The Parker Fly is no longer in production, so this jig assists in the recreation of Parker Fly style guitars. The process for using the jig is explained below:

- How to use the jig:
 - Place the fretboard in the bottom plate face down
 - Apply the selected epoxy to the back of the board
 - Place the sanded neck onto the fretboard
 - Place the hose to neck adapter block on top of the neck
 - Place hose that is connected to an air pump in the groove of the hose to neck adapter block
 - Place the L bracket on the tube as shown below
 - Engage clamps to stabilize all components
 - Fill the tube with 120psi of air pressure, or adequate pressure to ensure a proper bond
 - Let epoxy cure
 - Remove neck from fixture
 - Sand away any excess epoxy from the sides of the neck

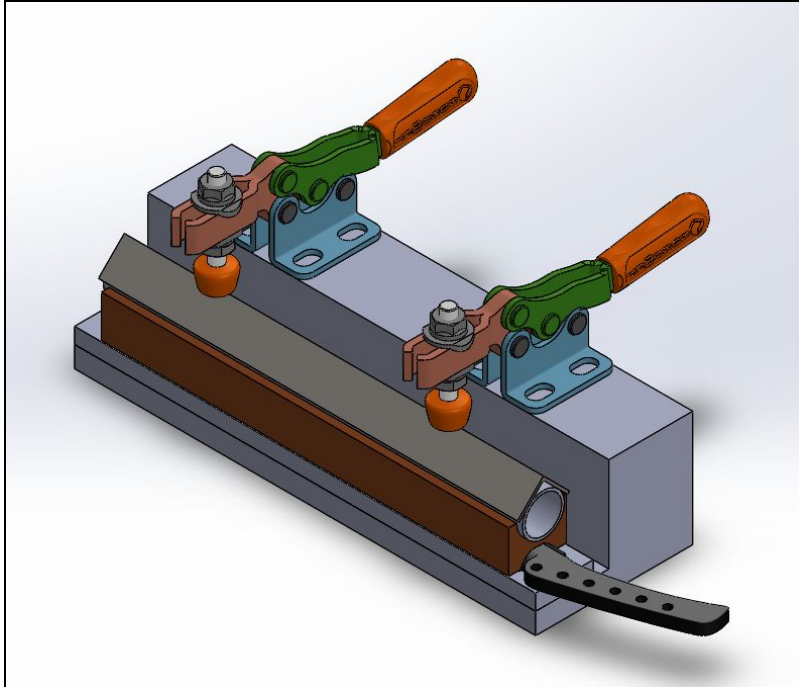

Full Assembly of Jig Concept

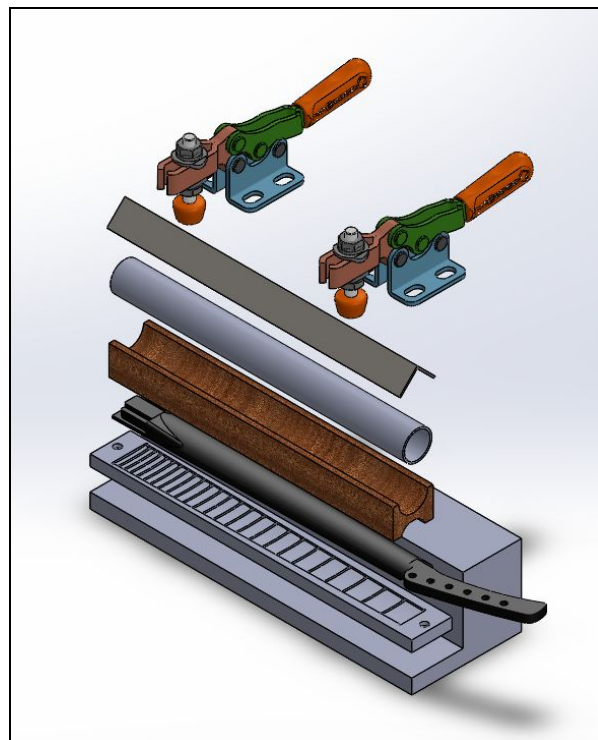





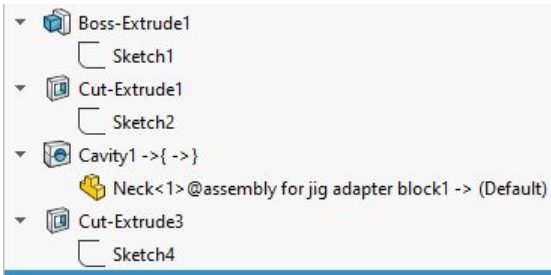
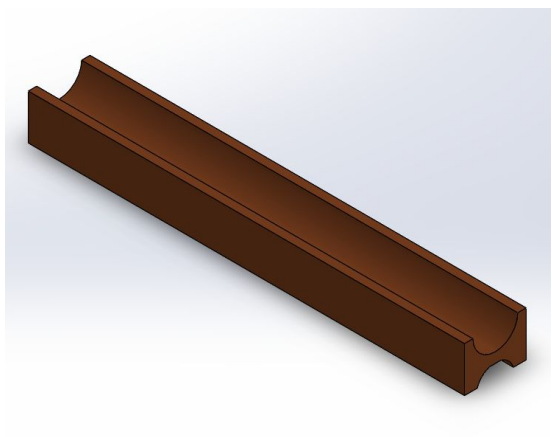

Exploded View

It is important to understand that this model does not fully represent what the final jig should look like. This assembly shows how the components should be connected relative to each other. For example, the jig base does not need to be large and blocky. The actual jig base

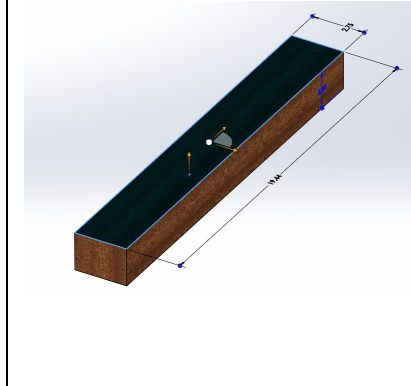
dimensions must be determined after all other components are purchased. The diameter of the hose and height of the clamps both affect how tall the jig will need to be physically made. This model mainly shows a concept that can only be refined through actual construction and testing.

The design of the jig was based on a previous design used to make Parker Fly guitars that can be found in a video on the WPI Parker Fly Project Wiki page. This style of jig allows the fretboard to be affixed to the neck without damage due to the perfect contour of the fretboard to neck plate. However, it is important to note that the contour of the plate was based off of a provided Parker Fly guitar neck model that was assumed to be true to the real thing. The jig should work for both 24 and 22 fret necks. In order to work with a 22 fret neck, the neck must be placed in the jig so that the nut is pushed as far forward in the bottom plate as possible. Detailed tables are shown below describing how the models were created for the various parts used in our Jig. The tables also specify why certain dimensions were selected and how to best edit the models.

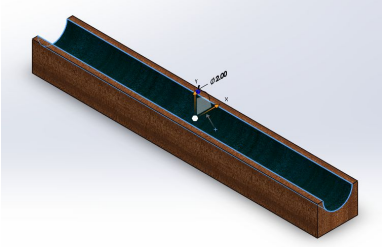
Hose and Neck Adapter Block		
		
		<p>The model started with the sketch of a rectangle that was extruded 2in. The length and width were selected to be long enough to accommodate the full length of the fretboard. The material can be any material that will not deform due to clamping pressure.</p>

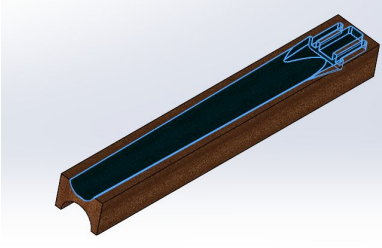
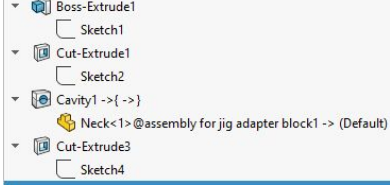
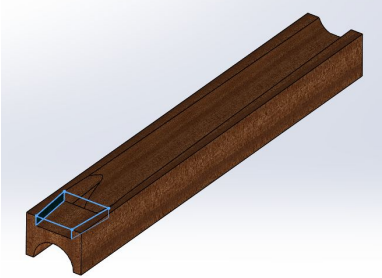
		<p>The extruded cut to allow the hose to fit was added next. The 2in diameter hole dimension was chosen arbitrarily and should be modified to accommodate the exact dimensions of whichever hose is purchased.</p>
		<p>The next feature used was the “cavity” feature. This feature allows the user to create a mold based off of existing parts. The back of the pre-modeled parker fly neck was used to create this cavity feature. NOTE: should the parker fly neck model be incorrect, the parker fly neck model will need to be updated to allow this jig to function properly.</p>
		<p>Lastly, unnecessary geometries were removed. The pressure should be evenly distributed enough for these geometries to be removed. The removal of these geometries is beneficial for the physical construction of the model. However, this model could still be optimized to allow for more efficient machining.</p>

Fretboard to Neck Adapter Block

- ▶ Boss-Extrude1
- ▶ Cavity1 ->{ ->}
- ▶ Cut-Extrude1
- ▶ CBORE for M5 Hex Head Bolt1
- ▶ Cut-Extrude2
- ▶ Cut-Extrude4
- ▶ Cut-Extrude5
- ▶ Cut-Extrude6

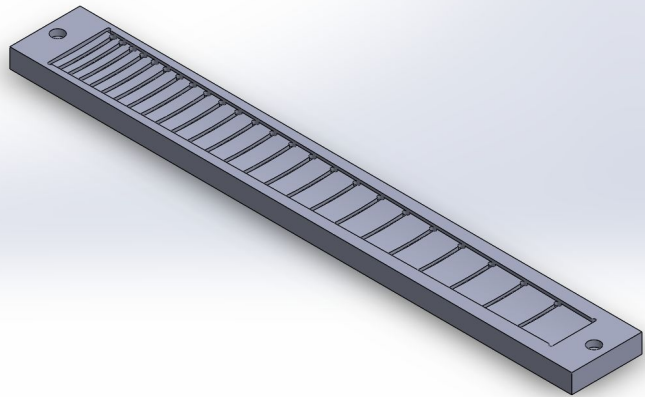

- ▼ Boss-Extrude1
 - Sketch1
- ▶ Cavity1 ->{ ->}
- ▶ Cut-Extrude1
- ▶ CBORE for M5 Hex Head Bolt1
- ▶ Cut-Extrude2
- ▶ Cut-Extrude4
- ▶ Cut-Extrude5
- ▶ Cut-Extrude6

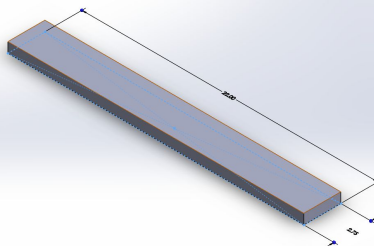

This model started with the sketch of a rectangle that was extruded. The dimensions were chosen to allow a full 24 fret fretboard to fit within the dimensions and to also have room for fixture holes. The material can be any material that will not deform due to clamping pressure. Currently, there is a CAM path for this part with a designated material of aluminum.

- ▼ Boss-Extrude1
 - Sketch1
- ▼ Cavity1 ->{ ->}
 - Neck<1>@assembly for jig an
- ▶ Cut-Extrude1
- ▶ CBORE for M5 Hex Head Bolt1
- ▶ Cut-Extrude2
- ▶ Cut-Extrude4
- ▶ Cut-Extrude5
- ▶ Cut-Extrude6

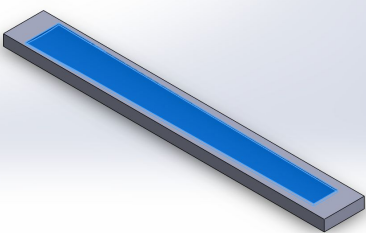

The next feature was the “cavity” feature. This feature created a mold of the current 24 fret parker fly neck model. NOTE: Should the parker fly neck model prove to be inaccurate, this feature will need to be updated with the correct model.

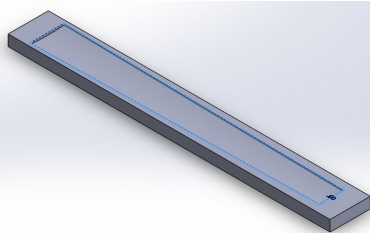
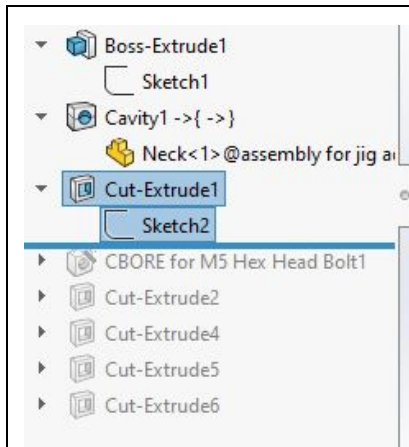

Next a sketch was created that used the edges of the fretboard cavity as a direct offset. This sketch was extrude cut to allow the physical neck to fit inside during use. Right now, this shape is a true perfect fit. This pocket may need to be slightly enlarged to allow the neck to fit more easily.

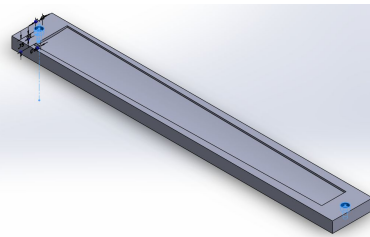
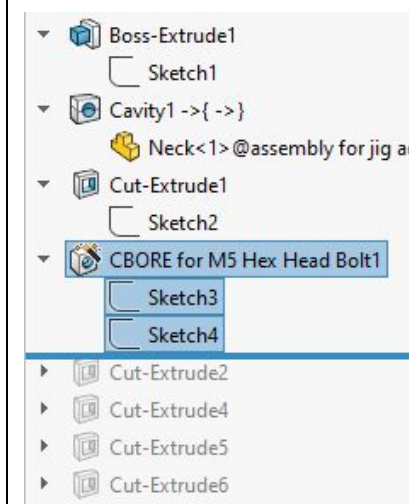

Two holes to allow for fixturing were added to the model. M5 holes were selected arbitrarily and can be changed to any dimension. The number of holes is also not important and can be changed.

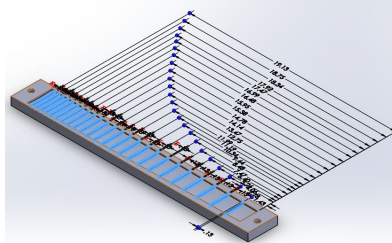
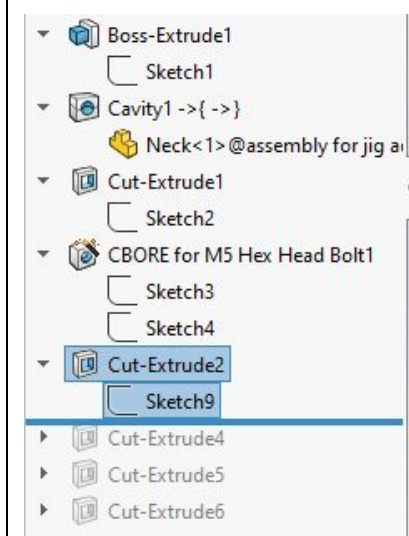

This next step is very important as it allows the frets to not have pressure placed on them during the use of the jig. The location of each extruded cut rectangle was decided using an online fret location calculator using guitar scale length. The width of each cut was decided to be .125in to match that of a 1/8in machining tool. Each fret is .1in, so this should be enough room. NOTE: If the width of the cuts needs to be changed, only change the dimension of the first fret because the rest of the frets will update

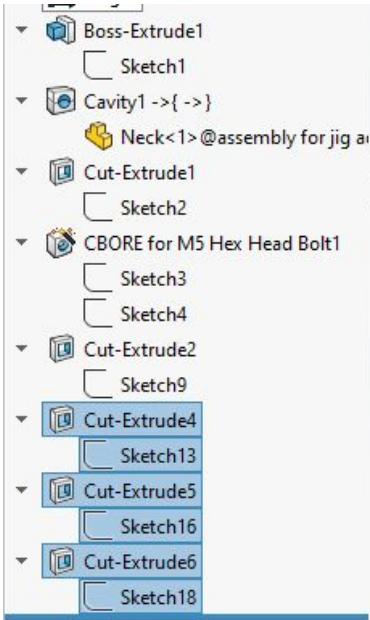
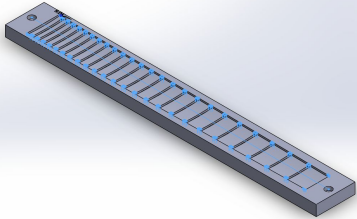
		automatically
		<p>The rest of the features are all extruded cuts. These features were added solely to allow for optimal machining. Machines cannot cut internal corners, so these features remove all internal corners that were contained in the model.</p>

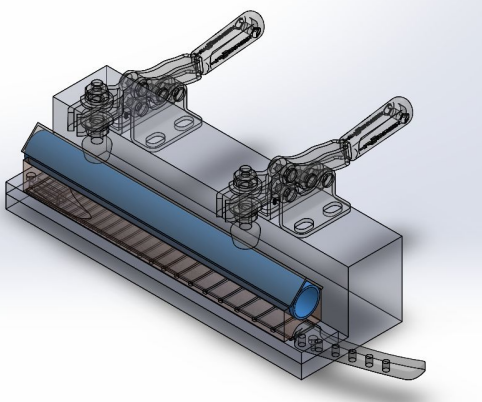
Placeholder Models	
<p>The following models were modeled in order to show the overall concept of the jig. These models should be updated to reflect whichever components eventually do get purchased.</p>	
<p>Hose:</p> 	<p>The “hose” model shows a tube model with a 2in outer diameter. The physical hose purchased does not have to be 2in. NOTE: the neck to hose adapter model should be changed to accommodate the diameter of the hose purchased.</p>

L Bracket:

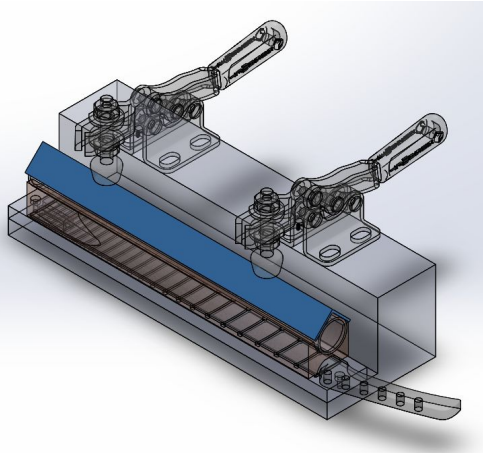

The L-Bracket component will accommodate any diameter hose because technically it will only touch the hose in two locations. However, the lengths of each side will need to change based on the diameter hose purchased to prevent the L-Bracket from hitting the top of the hose to neck adapter block. Right now, the lengths of the sides are 1.75in, but that measurement can be changed.

Clamps:

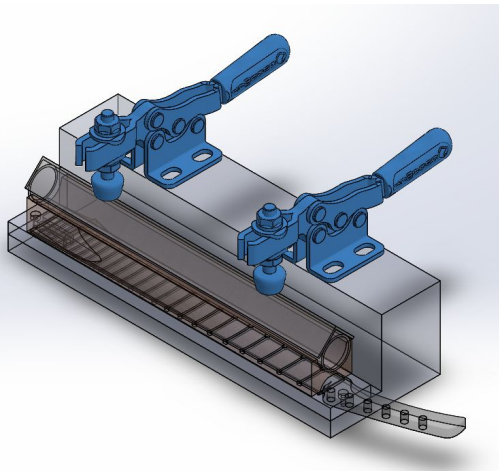

The clamps shown here are table mounted toggle clamps. These clamps act to hold the L-Bracket in place before the hose is pressurized. The number of clamps in this case is 2 because that is the number that was seen being used previously by luthiers. It is also recommended to modify the clamping tip of the clamps to fit the 90 degree corner of the L-Bracket.

Jig Base:

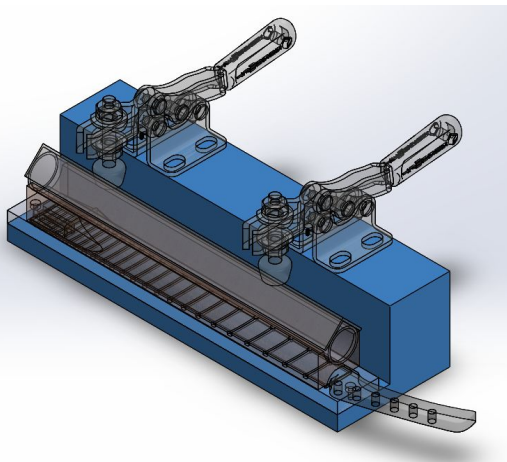

The base of the jig must be modified to accommodate whichever clamps are purchased. This part is probably the part model that will be changed the most when it comes to actual jig construction. The base needs to have a location where the clamps are mounted and also the fretboard to neck adapter block. The overall size of the clamps selected will affect how tall and wide the base is. The base also does not need to be a solid block as shown in the picture. The base just needs to have the strength required to keep the jig together when pressure is applied.

Links to potential items that could be purchased for the jig:

L-Brackets:

1. <https://store.buymetal.com/stainless/angle/304-304l.html>

Hoses:

(We recommend lay flat tubing that will inflate when air is pumped in, ends can be constructed using a tube plug and an adjustable hose clamp)

1. <https://www.alibaba.com/showroom/lay-flat-tubing.html>
2. <https://www.jmesales.com/kuriyama-ironsides-3-in-heavy-duty-pvc-water-discharge-hose-hose-only/>
3. <https://www.msdirect.com/browse/tnpla/48572168>
4. <https://www.msdirect.com/browse/tnpla/48739932>

Clamps:

1. https://www.harborfreight.com/500-lb-horizontal-toggle-clamp-96233.html?cid=paid_google||96233&utm_source=google&utm_medium=cpc&utm_campaign=&utm_content=&gclid=Cj0KCQjw-r71BRDuARIsAB7i_QN1lQhZTtO9dXSK-lIuQNkPL8LQeDnVHj08OxEUR_jJ_U_tAt-m6eUaAiB6EALw_wcB
2. https://www.ajaxtoolsupply.com/hotocllouf1b.html?cmp=googleproducts&kw=hotocllouf1b&gclid=Cj0KCQjw-r71BRDuARIsAB7i_QOfCOh02qEZvKZTc_irG46M9DKbu_1ibi68E8_uGu3wU5G88eBQyHUaAqOIEALw_wcB
3. <https://www.thetoggleclampstore.com/>