

The Les Paul Electromechanical Pickup (E 2021)

David Tomer and Dan Mattison

Abstract

This is a continuation of a project starting in C term 2021. We have continued to progress the first physical working electromechanical guitar pickup designed by Les Paul in 1959.

This project was completed over the course of E term 2021. During this summer, Washburn Shops was being reorganized, causing us to have multiple hold ups, and not having access to some machinery.

The goal of this project was to test and advance the electromechanical pickup, in efforts to put it into a guitar body.

Background

Electric guitars use magnetic pickups to generate an electric signal that is created by the motion of its strings when played. This electric signal can then be connected to an audio jack and be amplified through speakers.

In 1959, Les Paul created a patent for an electromechanical pickup. This pickup is different in the way that the bridge of the guitar is connected to the top of the pickup itself. This couples the motion of the strings to the pickup's coil or it's magnetic core.

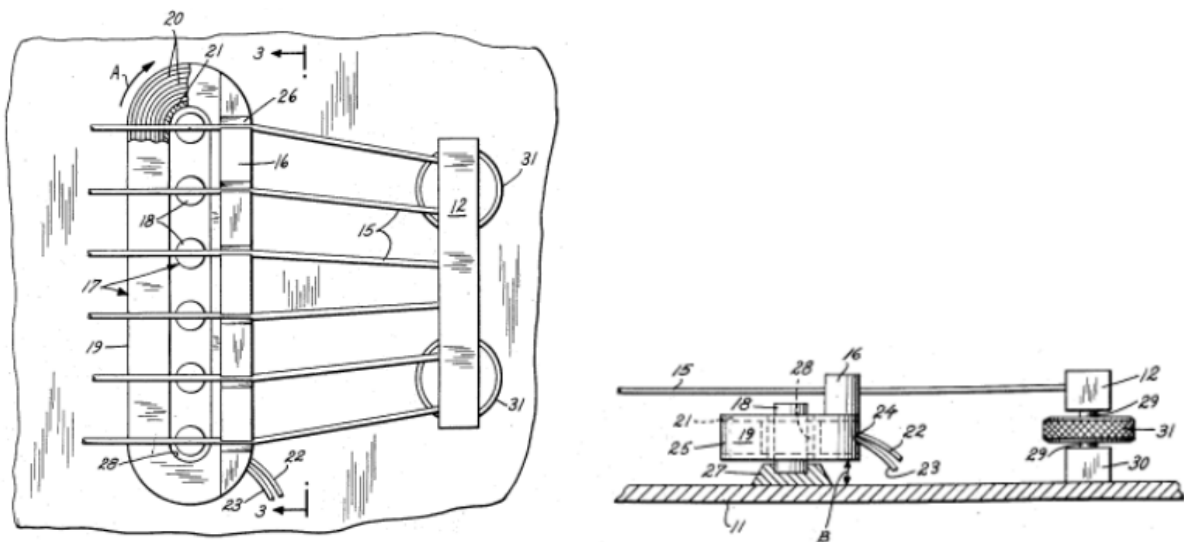

Figure 1: Original patent by Les Paul

Design

The D term team left us with two wound bobbins, an aluminum yoke, several 3D printed yokes, and a guitar test rig. The design of this bobbin allows the motion of the strings to be coupled with the coils, by sliding up and down on magnets connected to the guitar body.

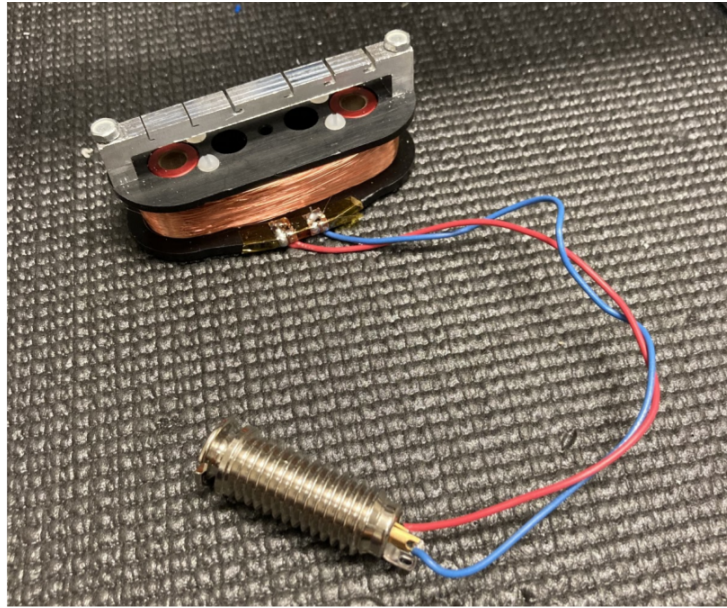

Figure 2: Finished bobbin with aluminum yoke.

The guitar test rig allowed us to easily test the pickups without needing to restring each test.



Figure 3: Guitar test rig

We hooked the pickups to the test rig to see how they sounded. These pickups were very noisy and upon inspection of the materials we were left with, we identified several areas where the pickup and test rig could be improved.

The first problem we found was that the wrapped wire on both bobbins was coming loose. We then cut the wire off so that we could re-wrap them more tightly. Additionally, we wanted to adjust the number of wraps and ultimately the DC resistance of the pickup design. We researched typical bridge position pickups in both strat and tele style guitars, and what resistances they normally have. We found that they typically have a resistance of 6-7k ohms. This was the target resistance we had when wrapping the bobbins.

Another problem discovered by the team in D-term was that the thread inserts were bending inside of the 3D printed module on the testbed, and the strings would not hold a tune. To fix this we decided to make one out of wood because ultimately a guitar is made of wood so it would be a more accurate representation than 3D printed material. We also 3D printed a new module in case the wooden module didn't work, and because we could create it quickly.

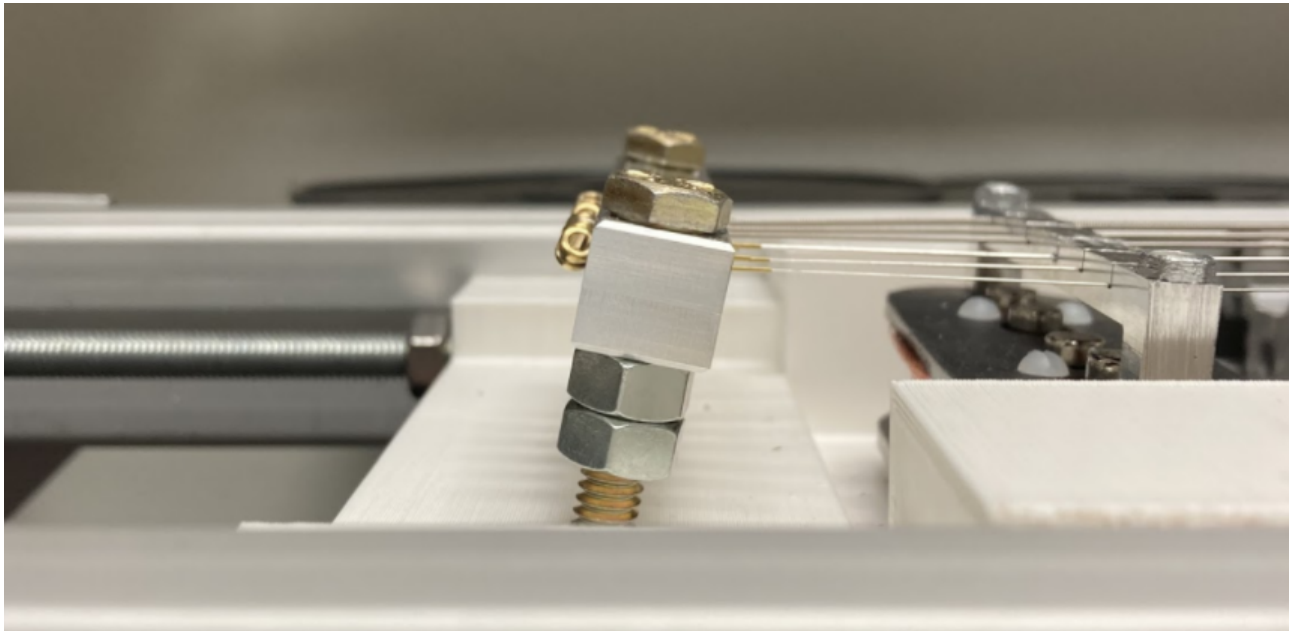

Figure 4: Old tailpiece module with bending tailpiece

The D-term team also indicated a problem they encountered when manufacturing the yokes. They encountered an issue when using the EDM to cut the notch for the G string. It was cut too small and had to be widened by hand. We machined a new yoke to fix this issue.

Finally, we wanted to explore different options for bearings inside the bobbin. With regard to the fit of the previous bearings on the magnets, we measured the freedom to be about .0005”-.002” radially on the magnet (.001”-.004” total freedom). We would expect numbers closer to .0025”-.005” of freedom radially. This was the dimension we were looking for going forward with testing different bearings or bushings. We selected a linear bearing and a brass oil-coated bushing. In some cases, we used the previous linear bearings used to test by the D term team.

Manufacturing

In addition to the components left to us by the D-term team, we decided to build two more bobbins, a new tailpiece module, and a new aluminum yoke. The last team created ESPRIT programs to generate G-Code that the Mini Mills can read. Within ESPRIT, different milling tools can be selected for the defined tool paths. Of the already existing ESPRIT files, our team with the help of a lab monitor changed a small part of how the yoke would be machined. We were also left with Solidworks files for each part that could easily be edited or 3D printed.

Bobbin

To recreate two more bobbins we ordered Delrin, a strong plastic that would not deform while it's being machined. To create the bobbins, we needed to machine two pieces of Delrin, the top and bottom of the bobbin.



Figure 5: Top and bottom of bobbin machined out of Delrin

The stock Delrin for the bottom was 1" thick by 1 1/2" wide, while the top was 1/4" thick by 1 1/2" wide. Both pieces were then cut to a length of 3 1/4" long so it could be fastened into a MiniMill without wasting material that would be cut away. Both pieces were machined in two operations, once to cut the top of the block, and then the block was flipped over so the bottom could be cut. The bobbin bottom easily fit in the Mini Mill vise and did not need special fixturing. The Delrin used for the bobbin top was too thin to be held in the vise by itself. In order to cut it, we got a scrap piece of aluminum to attach the Delrin to, so that there was more buffer space between the Delrin and the vise. To attach the Delrin to the aluminum, masking tape was applied to the top of the aluminum and the bottom of the Delrin. Both sides with masking tape were then superglued together and clamped for 30 minutes to allow the glue to cure. Once cured the piece of aluminum could be easily secured into the vise. Delrin and aluminum require the same cutting speed on the milling machine, therefore there is no issue cutting into the attached aluminum if needed.

Bobbin Winding

From research on other bridge pickups, we were looking to get a resistance of around 6.5k ohms. Through a process of trial and error, we found that to achieve a resistance of 6k-7k ohms, the number of winds should be between 7500 & 8000.

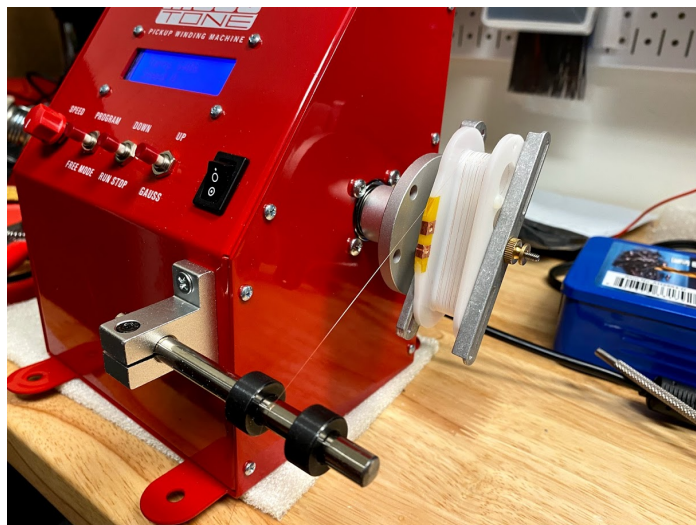

Figure 6: New bobbin attached to the pickup winding machine

Tailpiece Module

To try and fix the tailpiece from bending forward due to the tension of the strings, we created two new modules. One was 3D printed with a slightly larger shell thickness so that the piece would be sturdier all around.

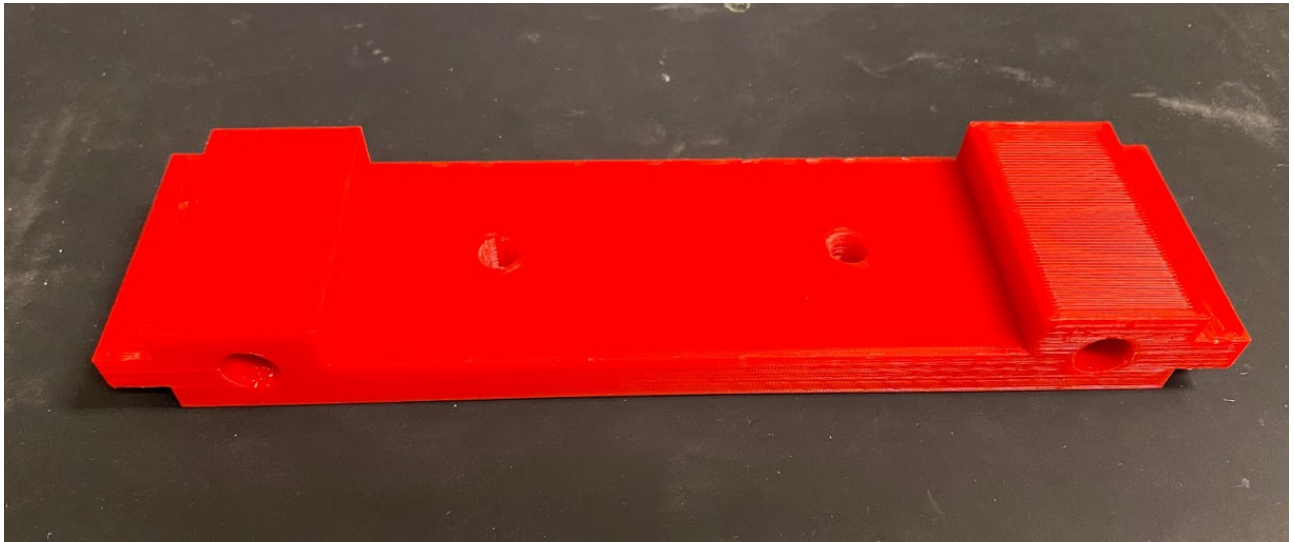

Figure 7: New 3D printed tailpiece (filename: tailpiece_bridge_block_wood)

We also constructed a tailpiece module out of wood. Ideally, we would have used a CNC machine to cut the wood to an exact fit for the guitar test rig, but we were not able to get access to it due to many of the machines being moved. A table saw set to the correct height was used to cut the top and bottom of the ends of the block of wood. This was done to create a protrusion on each end of the block so that the wood could fit into the grooves of the test rig. A drill press was then used to form the holes for test rig bars and the tailpiece screws. The screws in the new tailpiece were still pulled forward with this design, but the strings held their tune for longer. This issue could be lessened by using the method below to install the tailpiece into the physical guitar body.

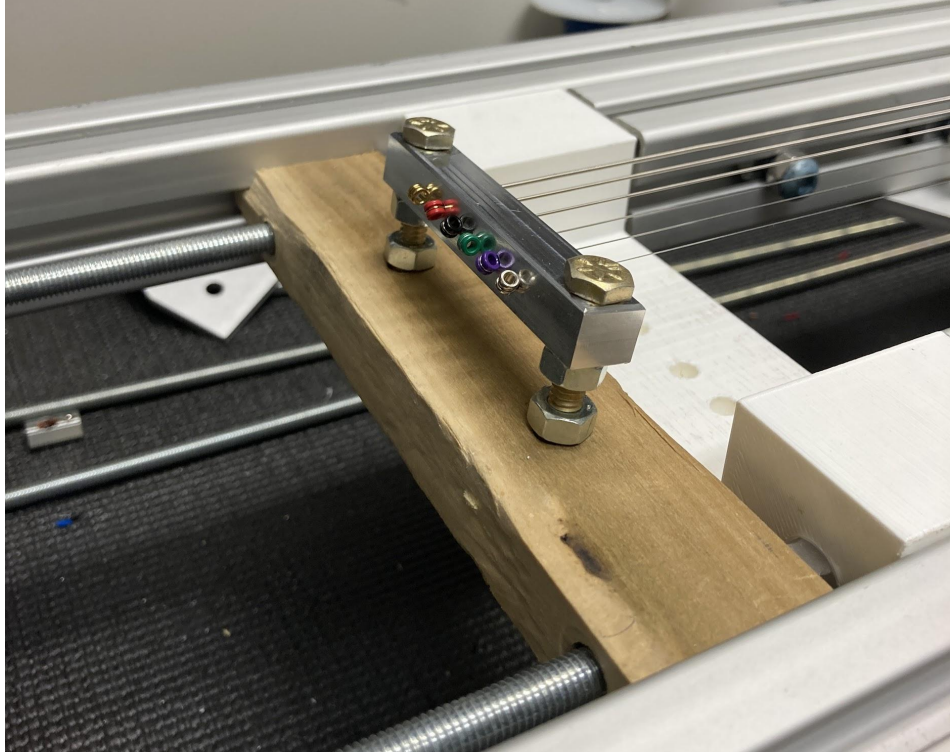

Figure 8: Wooden tailpiece module

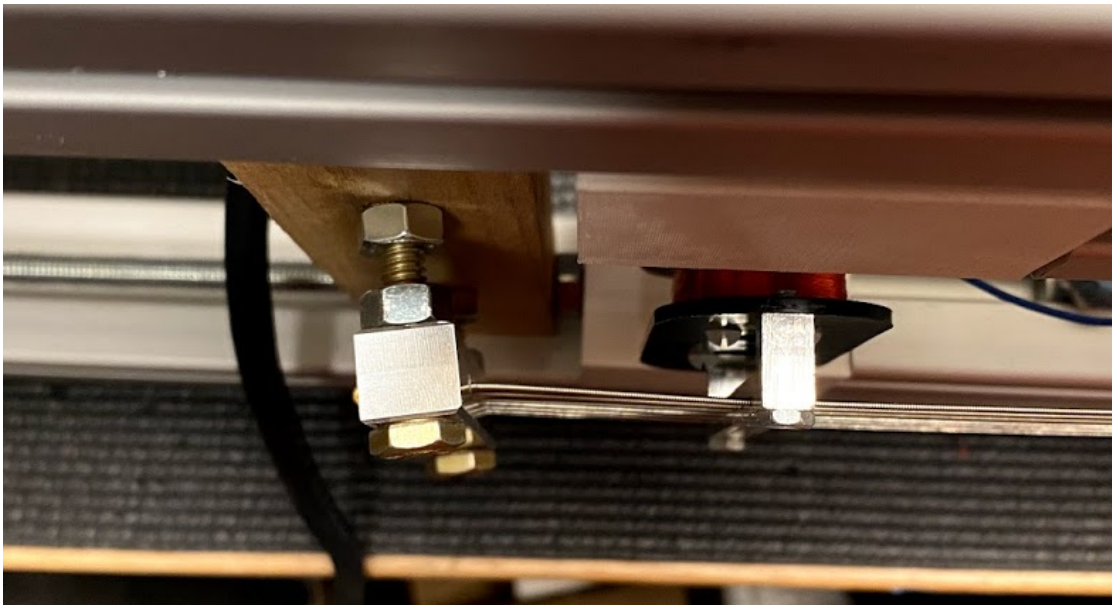

Figure 9: Tailpiece pulled forward in the wooden module

Yoke

The machined slot for the G string on the aluminum yoke created by the previous team was too small to fit the groove. They then used an abrasive string to widen the slot and left a very rough surface. We decided to machine another aluminum yoke to get a better cut for the G string. Another reason we wanted this yoke was so that two pickups could be fully assembled at the same time. That way one could be used in the test rig while the other could be placed in an actual guitar body.

To machine the yoke, a piece of aluminum was cut to 3 1/4" long by 3/8" thick by 3/4" wide. This was done in 3 operations. The first operation drilled the holes and carved the shape of the yoke. The second faced off the other side. The third uses the wire EDM machine and cuts the grooves for the strings. In order to use the wire EDM, a fixture was created so that the yoke could be safely secured into the machine. This fixture was just another piece of aluminum, about the same thickness as the yoke. Two holes were drilled and threaded so that the yoke could be screwed into it.



Figure 10: New Yoke on EDM fixture plate

To solve the previous issue of the cut made for the G string, a lab monitor helped us do some test cuts for that specific size. After many test cuts, we figured out that the string would fit into its slot if the wire EDM followed the path to cut the G string twice, effectively eliminating any burrs and roughness that may have been left by the initial cut.

Guitar Body

We were able to use one of the guitar bodies already available in the lab to put this pickup into. The pickup did not fit in the already existing holes in this guitar body. We 3D printed a routing template so we had a guide to follow to rout out a new hole to fit the pickup in.



Figure 11: Guide for routing out the hole to house the pickup in the guitar body (file name: Guitar body routing template)

The distance from the nut of the guitar to the 12th fret should be the same distance as the distance from the twelfth fret to the bridge or yoke. In our case, this distance from the nut to the yoke should be 25.5 inches. Since the yoke sits on top of the bobbin in our design, this is the distance where the new hole for the pickup was routed out.



Figure 12: Guitar body with hole routed out to house the pickup

The route in the guitar body ended up being too deep for the pickup to sit in. We then designed an insert that could be printed and placed in the guitar. The insert also acted as a positioning template for the magnetic poles for the pickup. The magnets were superglued into our 3D printed insert, then the insert was superglued into the guitar.



Figure 13: Guitar route insert (file name: Guitar body insert)

After the hole was routed, we needed to install the tailpiece. Given the trouble both us and the previous team had with the tailpiece bending, we decided to use more thread inserts in the guitar. Rather than only one per side, we used three. They were threaded onto the bolts and then hammered into the holes in the guitar body. This ensured that the threads lined up with the bolts after they were inserted into the guitar.

We soldered the Les Paul pickup into a pickguard with a tone, and volume knob, and a 3 way selector switch. The Les Paul pickup is wired so that it is selected when the switch points up toward the strings.



Figure 14: Thread inserts on bolts before installation

Even though we used 3 thread inserts instead of one, the tailpiece still bent a bit forward under the tension of all the strings.

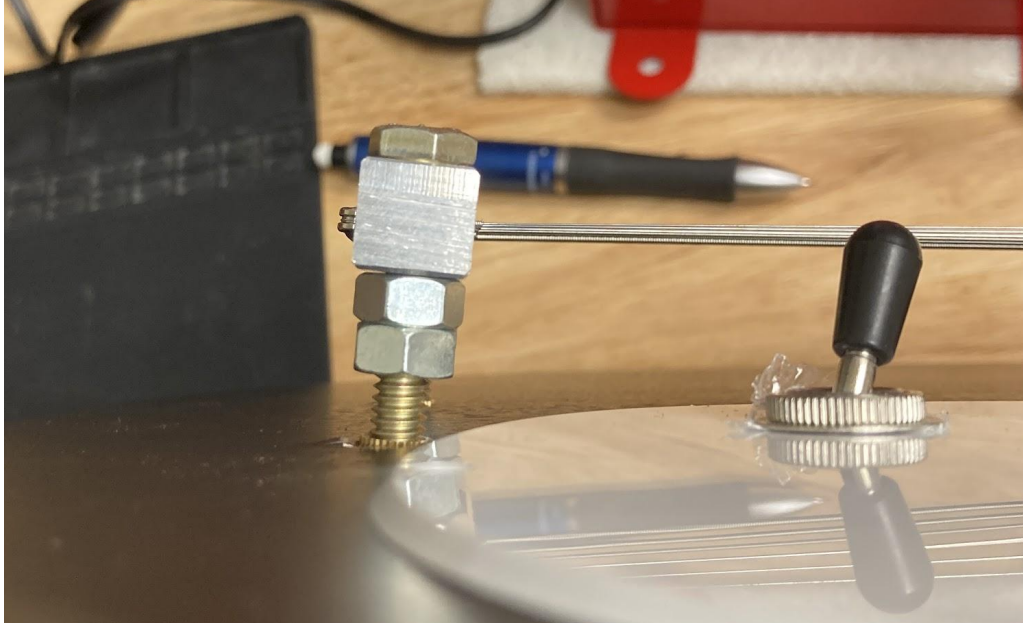

Figure 15: Bent Tailpiece in Guitar



Figure 16: Fully assembled pickup in the guitar

Testing

Once the bobbins were wound and the new wooden tailpiece was cut we were able to start testing the pickups. The bobbin on the test stand was then connected to jack input 9 on the lab's RME which was also connected to the computer. Totalmix was used to set the gain and see the signal coming in. The gain was set to about 40 dB. Ableton Live was used to record the pickups. While using Ableton Live's recording feature, each individual string was plucked.

During testing, we wanted to try different combinations of resistances and bearing types. Throughout testing, we had to rewrap several bobbins while switching bearings around. At the end of it all, we determined that the new linear bearings worked the best, and a resistance closer to 7 Kohms sounded the best. We determined this mostly through qualitative observation of the behavior of the pickup on the magnetic poles, as well as the sound produced.



Figure 17: Guitar test rig with the bobbin and new wooden tailpiece module

Recommendations for Future Work

The biggest problem our team faced this term was the tailpiece. Both in the wooden module in the test rig, as well as in the guitar, it was still bending under the tension of the strings. Finding a better solution would help the pickup and guitar perform and play better.

Another area for improvement may be the yoke. When played, the pickup has this metallic timbre, which we believe is a result of the aluminum yoke. An investigation into the design of the yoke and its material could provide a solution to eliminate or mitigate this tonal effect.

The team in D term looked into a one-piece design for the bobbin early in their design. This approach could be researched again. The two-piece design does have some drawbacks. When wrapping these bobbins, a problem arises if the screws holding the top are not screwed down tight enough. The wire tends to slip in the gap that exists between the two pieces which can cause shorts in the wire, or it can break altogether. A single-piece 3D printable design would alleviate that problem. Another good thing about a one piece design is that it would make manufacturing easier. Through our testing, we broke 2 bobbin bottoms. The holes where the connections are soldered ended up melting on one of the bottoms. On the other, the heads of one of the plastic screws ended up breaking off, leaving the bottom part stuck inside the bobbin. A one-piece design would make replacing parts easier and faster.



Figure 18: Bobbin with melted connection holes

Although we made improvements over the D term design with the bearings, we believe there may still be a better solution that would allow the bobbin to move more freely on the magnets.