

Design and Manufacturing of a Testing Rig for Reverse Engineered Vibrato System

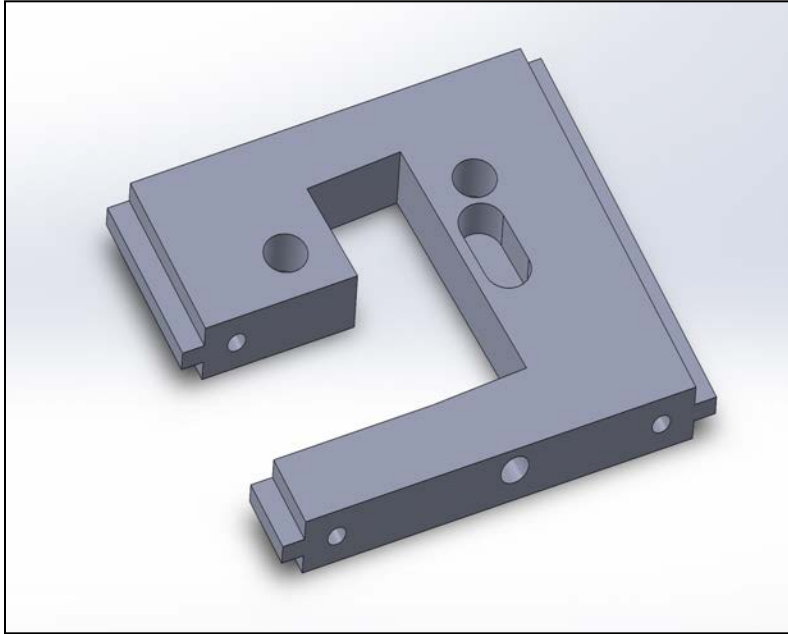

A Major Qualifying Project Report submitted to the Faculty of WORCESTER POLYTECHNIC INSTITUTE in partial fulfillment of the requirements for the Degree of Bachelor Science in Mechanical Engineering.

Submitted By:

Katherine Burkes (ME)
Lanna Delaney (ME)
Andrew Fauerbach (ME)

Project Advisors:

Professor Fiona Levey (ME)
Professor V.J. Manzo (HUA)

Date of Submission: April 28, 2022

This report represents the work of one or more WPI undergraduate students submitted to the faculty as evidence of completion of a degree requirement. WPI routinely publishes these reports on its site without editorial or peer review.

Acknowledgements

We would like to acknowledge all members that have contributed to the development of our flat spring. The team would like to thank Professor Fiona Levey and Professor VJ Manzo for their support and guidance. We would like to thank members of the Worcester Polytechnic Institute Mechanical Engineering Department, specifically Professor Adriana Hera with the assistance and advice to the use of ANSYS. We would also like to thank Reisyah Ichwani for her time in helping us with the SEM analysis.

Abstract

This project involved the reverse engineering of a flat spring used in the vibrato or “whammy bar” system of Parker Fly electric guitars. These springs fail in service and are no longer manufactured, leaving a potential market of 60,000 guitars in need of springs. The team investigated the mode of failure of the original springs. SEM analysis did not show any signs of fatigue, but ANSYS analysis and calculations showed buckling to be a potential mode of failure. Hardness testing showed that the original springs were harder than specification. The team designed and manufactured a testing rig as well as a die to produce springs that can be tested by guitarists.

Table of Contents

Acknowledgements	2
Abstract	3
Table of Contents	4
1.0 Introduction	5
2.0 Background	5
2.1 Traditional Vibrato Systems vs. Parker Fly Guitars	5
2.2 Flat Springs	8
2.3 Materials and Manufacturing	10
2.4 Stress, Strain, and Fatigue	13
2.5 Buckling Analysis	14
2.6 Ansys Workbench	14
2.7 Scanning Electron Microscope	15
2.8 Hardness Testing	16
3.0 Methodology	17
3.1 Objective 1: Identify Mode of Failure	17
3.1.1 3D Parts, Assemblies, and Ansys Analysis	18
3.1.2 Fracture Surface Analysis	23
3.1.3 Force Sensor Analysis	24
3.1.6 Survey	26
3.2 Objective 2: Process Design	34
3.2.1 Rig Manufacturing	34
3.2.2 Heat Treatment and Hardness Testing	35
3.3 Objective 3: Manufacturing Processes	37
3.3.1 Spring Manufacturing Process	40
3.3.2 Rig Manufacturing Process	43
4.0 Discussion	45
5.0 Conclusion and Recommendations	47
6.0 Broader Impacts	48
7.0 Bibliography	49

1.0 Introduction

In the 1990s, the company Parker Guitars produced and sold guitars known as the Parker Fly Guitars, popular for their resonating sound. The body, with an exoskeleton made from fiberglass and carbon fiber, is unusually thin, light in weight, and resonant. The inside mechanics of the Fly vibrato system employed a flat spring instead of a coiled spring in an effort to provide more nuanced control over the balance of string tension on the instrument while using the vibrato arm or “whammy” bar to change pitch. The company ceased production of the Fly and closed operations in 2015. The flat spring in the Parker Fly guitar is a novel approach toward vibrato system development and has not been explored further by other guitar manufacturers. The flat springs used in the Parker Fly are no longer in production and do break over time with usage, making them harder to obtain as the years go on. There is no public research or knowledge as to how or why the flat spring was made.

Preliminary analysis of the Fly springs began in Fall 2020 by a previous student team working with our advisors. Our goal was to design and manufacture a testing rig for the reverse engineered vibrato system used in the Parker Fly Guitar.

2.0 Background

2.1 Traditional Vibrato Systems vs. Parker Fly Guitars

The Parker Fly is unique in itself through its design and manufacturing, but also the mechanics of the vibrato system that facilitate changes in pitch through the use of a whammy bar, also known as the “tremolo” bar. The Fly bridge has two modes of operation: fixed and floating. Inside the bridge cavity of the instrument, a flat spring is placed between a three ridged spring plate and T-bar. The T-bar is attached to a tension wheel by a threaded rod and the function of the wheel is to compress the spring or allow the spring to expand depending upon the direction the wheel is turned. This tension wheel, when turned, moves the threaded rod and the threaded rod pushes a T-bar against the spring. When the wheel is turned downward, the tension on the spring is increased, thereby increasing the force on the spring. When the wheel is turned upward, the threaded rod recedes into the cavity in the body and the tension on the spring is reduced, thereby decreasing the force on the spring. Using the tension wheel, a balancing point is found so that strings are in tune and the three ridge spring plate is just barely touching the step-stop. When the whammy bar is pushed down the three ridge plate is what moves and applies force to the spring. The step-stop, as seen in Figure 1, can be kept in place or moved out of the way which will move the bridge between a fixed position or a floating position. The floating position allows for the whammy bar to be pushed or pulled. By moving the step-stop out of the way the spring is able to expand when the whammy bar is pulled and contract when the whammy

bar is pushed. The fixed ridged spring plate is connected to the bridge that's connected to the whammy bar. As the whammy bar is pulled or pushed it forces the ridged spring plate to move back and forth causing the flat spring to compress or expand and revert back to its normal shape. The strings, when tuned (tightened), place a force on the flat spring without force being applied by the whammy bar. When the whammy bar is used, the spring is subjected to additional force exerted by the motion of the three ridge plate. The purpose for this is to change the pitch produced when one or more strings are strummed or plucked. When a guitar string is struck and the whammy bar is moved, the sounding pitch is temporarily changed up or down depending on the direction the whammy bar is moved. The Parker Fly guitar spring system with all of its parts labeled can be seen in Figure 1.

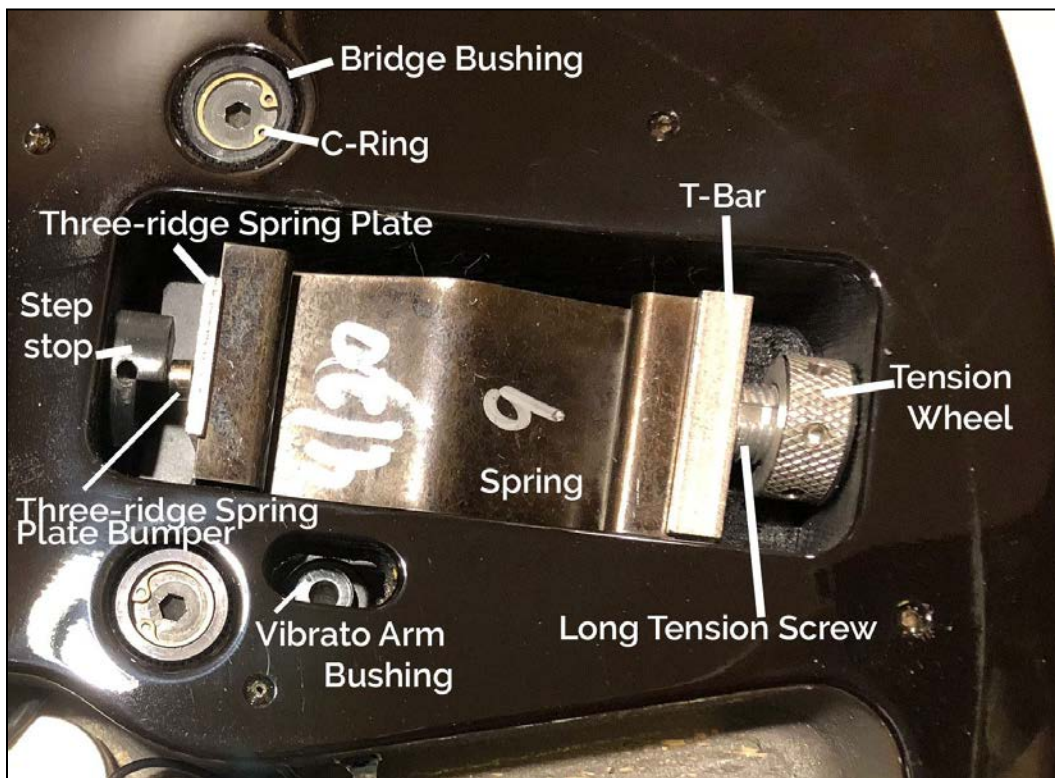

Figure 1: Spring system in a Parker Fly guitar (Courtesy of Professor Manzo)

By contrast, Fender Stratocasters and many other guitars have vibrato systems equipped with several (usually three to five) cylindrical spiral extension springs that attach to a spring plate, or tremolo block, on one end. In such a system, the other end of the springs are attached to a metal plate, or tremolo claw, and the plate is secured to the body of the guitar as shown in Figure 2; a diagram of these springs in the context of the entire typical vibrato system is shown in Figure 3.



Figure 2: Typical spring system for a guitar's vibrato system

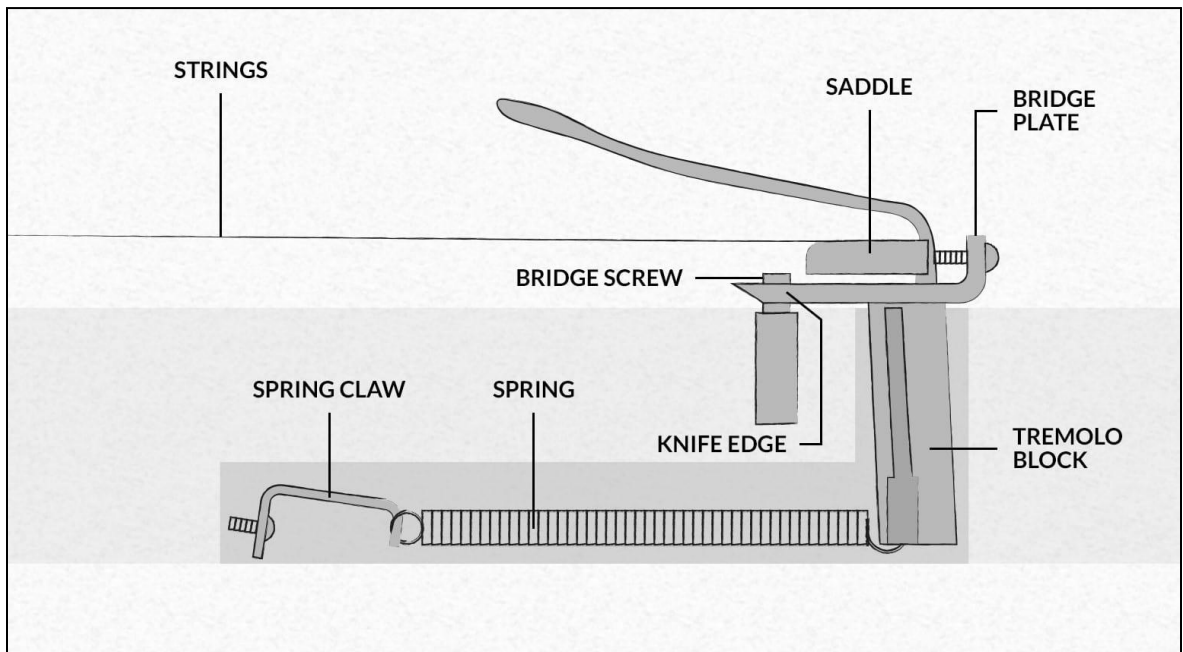

Figure 3: Diagram of the entire typical vibrato system

An ongoing problem with many vibrato systems in electric guitars is the propensity for the strings to go out of tune when the vibrato arm is used. Regardless of the specific vibrato system used, the basics of this action is that when the vibrato arm is used, it pulls on the strings. Because the strings are held on one end by being wound around tuning pegs, the extra tension effectively loosens them. This changes the frequency at which the strings vibrate when played, thus changing the pitch of the string causing it to sound “out of tune”. There have been many attempts to combat this issue, including the use of locking nuts that clamp the strings in place. The Parker Fly utilizes Sperzel locking tuning keys to clamp the strings in the jaw of a tuning

peg in order to prevent string-slipping during vibrato usage. This makes any slip while using the vibrato arm much less prevalent than winding and tying the string to a traditional tuning peg.

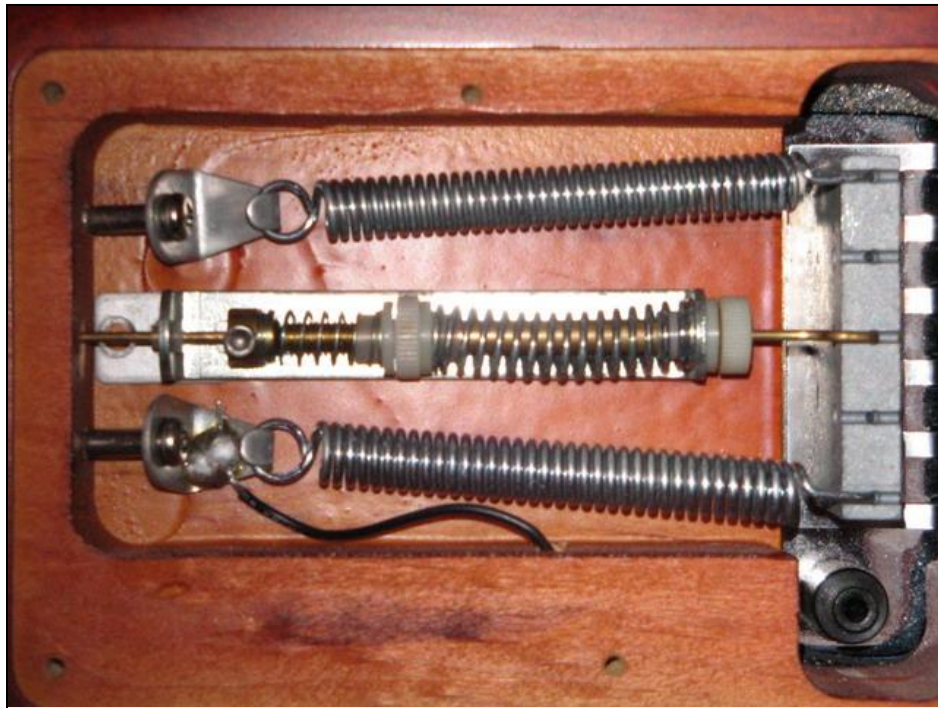

Figure 4: The Hipshot Tremsetter stabilizer replaces the central spiral extension spring

The use of a flat spring in the Parker Fly vibrato is a noteworthy difference from the vibrato systems of other guitars. The step stop in the Parker Fly guitar is also noteworthy in that it allows the vibrato system to easily change between fixed and floating modes once the spring has been properly tensioned unlike other vibrato systems, which require a more significant adjustment to switch from a fixed vibrato mode or full floating mode.

2.2 Flat Springs

Generally, when a person visualizes a spring they think of a coiled piece of metal. There are two types of this kind of spring: compression and extension (Figure 5).

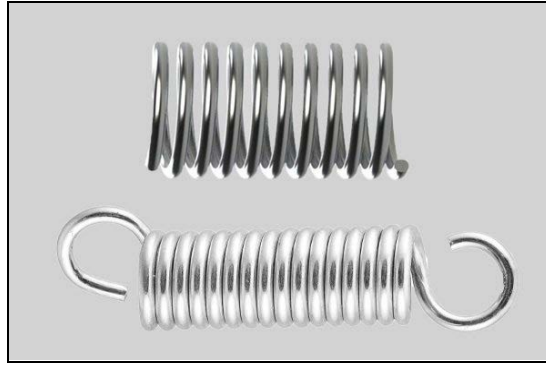

Figure 5: Image of compression spring (top) and extension spring (bottom) (JB Springs)



Figure 6: Example of flat spring (Irvine Springs)

Compression springs have forces pushing out on both ends because they are trying to keep components from coming together. While extension springs have forces pushing in because they are trying to hold two components together. Flat springs are a flat strip of material, normally made from metal and used where space is limited. They are not coiled like other ordinary springs, instead they have a curve to them, as seen in Figure 6, making them easily recognizable.

Flat springs are made from metal stock, customarily made from AISI 301, 302, 304 stainless steel and shaped into the intended design. They can also be manufactured from “high carbon spring steel, nickel-silver, high-nickel alloys, phosphor-bronze, and beryllium-copper combinations” (Stevenage Spring Co Ltd). When choosing stainless steel to make a flat spring, it offers better protection against corrosion, however high-carbon flat springs are much stronger, and therefore able to support heavier loads. High-carbon flat springs made from AISI 1095 have a carbon content of 0.9-1.04% and have a yield strength of 525MPa.

Flat springs are used for an array of industries for instance: motors, office equipment, medical equipment, counterbalances, and electric appliances. Within electrical appliances they serve as contacts; because of this the flat springs are put through copper, tin, silver, or gold plating, allowing the flat spring to be even more conductive, durable, and resistant to corrosion (European Springs & Pressings Ltd).

There are variations to the flat spring, such as leaf springs and flat coil springs. Leaf springs are found in vehicles and are important in parts of suspension. The name leaf spring comes from a number of leaves laying on top of each other with a range in sizes. The larger layer

is on top with layers ascending down having one end or both ends attached to the body or frame of the vehicle. The purpose of the leaf spring is to provide support to the passenger while riding “by minimizing the vertical vibration caused by the nonuniformity of road geometry” (Pradeep, S. A., Iyer, R. K., Kazan, H., & Pilla, S., 2016). Flat coil springs are used to control the movement of valves found in vehicle exhaust systems/motors, steering wheels, clocks, watches, medical and industrial equipment. Flat coil springs are flat pieces of metal spiraled out to absorb shock or provide tension (Figure 7).



Figure 7: Image of flat coil spring (Irvine Spring)

The flat spring used for the Parker Fly was designed with a flat piece of metal slightly bent in the middle and having each end shaped into an S. The reason for this unique design is unknown.

2.3 Materials and Manufacturing

The springs used in the initial manufacturing of the guitar were made out of AISI 1095 annealed and tempered steel coated with zinc nickel and trivalent chromate. AISI 1095 is a high carbon spring steel with low hardenability. It has many different applications including but not limited to flat springs, coil springs, drills, cutting tools, and ball bearings (AISI 1095 (High-Carbon Steel), 1952).

The spring steel was purchased as sheet metal already coated with zinc-nickel and trivalent chromate. Zinc-Nickel is an effective coating used to protect against corrosion. This method is called cathodic protection. Specifically, zinc-nickel alloys are used in a technique that utilizes galvanic couples. In this technique, zinc-nickel alloy is electrically connected with a less reactive metal like 1095 steel. When the former oxidizes, it gives up electrons, and protects the steel. Galvanization is done by hot dipping the surface of the steel in a layer of zinc-nickel. If surface damage is present in the steel, the zinc will protect it from further corrosion (Callister, W. D., & Rethwisch, D. G., 2014). Trivalent chromate is typically painted on zinc coated pieces to

further protect against corrosion and rust (Electrochemical Products Inc, n.d.). This coating must be allowed to dry for at least 24 hours, or can be cured with heat for a faster drying time.

AISI 1095 commonly is hardened by a process called austenitization followed by quenching in water and then tempering. Figure 8 shows the isothermal transformation diagram of 1095 steel. Austenitization occurs in 1095 steel when heated to 1625°F. At this temperature the crystal structure transforms into austenite. This microstructure is a face-centered cubic structure. Once this point is reached, the rate at which the metal cools determines its new microstructure. In order of decreasing cooling rate these potential microstructures are martensite, bainite, ledeburite, cementite, pearlite, and ferrite (Heat Treatment, 2004).

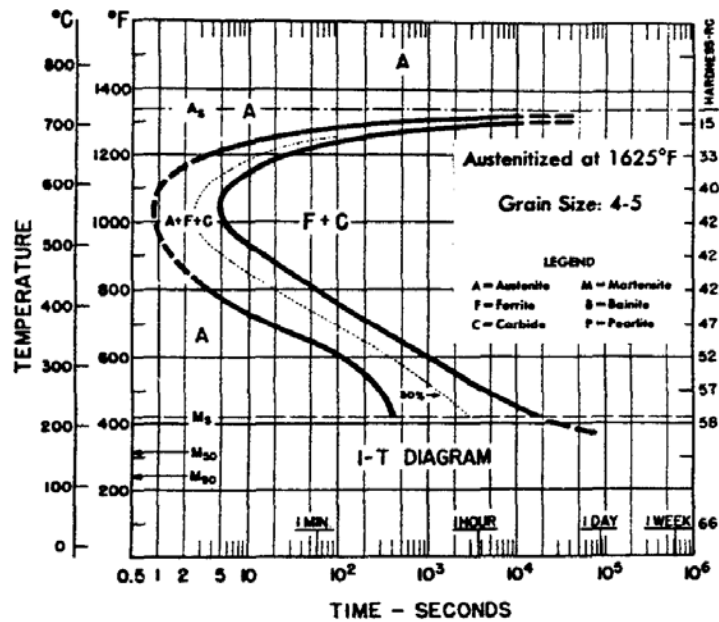

Fig. 1 — Isothermal-transformation diagram of AISI 1095 containing 0.89% carbon and 0.29% manganese.

Figure 8: Isothermal Transformation diagram of AISI 1095 steel (AISI 1095 (High-Carbon Steel), 1952)

The original flat spring used for the Parker Fly was likely cold worked. Cold working is when the metal is plastically deformed below the recrystallization temperature (Callister, W.D., & Rethwisch, D.G., 2014). This was likely done in an annealed state, making the metal extremely ductile. After the spring has its shape, the spring would have been austenitized. This process involves heating the carbon-steel above its austenitizing temperature, allowing the carbides to fully or partially dissolve. Usually, this happens at high temperatures, but very little time in the heat treating oven. After being held at this temperature the springs were either water or oil quenched. The quenching medium controls the rate at which the springs cool. Water will cool the springs very quickly, while oil will cool the springs at a slower rate. The process of quenching will result in martensitic microstructure, which makes the springs very brittle and with residual stresses. Water quenching makes springs harder and more brittle than oil quenching. To

relieve residual stresses and to reduce the amount of martensite present to achieve the ideal hardness of the springs, the springs must then be tempered. This means heating the springs and holding them at high temperatures for a longer period of time, and then air cooling until room temperature. This process is to ensure the spring has a bainitic microstructure.

Though AISI 1095 steel is a common spring steel, there are comparable steels to be considered. AISI 5160 is a medium carbon alloy steel typically used for heavy duty machinery. Its uses include but are not limited to gearing, shafting, tools, and springs. It also is 1% chromium by mass. Though it has high hardenability and strength, it is particularly susceptible to rust and corrosion. The chromium content of this alloy is added for this reason, to prevent rust. Unfortunately, in such small quantities it is not enough to protect it from corrosion. AISI 5160 is hardened by heating it to temperatures between 1525°F and 1575°F and quenched in oil. It is commonly annealed at temperatures between 1450°F and 1550°F and allowed to cool slowly (AISI 5160 (High Strength Machinery Steel), 1952). The cooling transformation diagram for AISI 5160 is shown in Figure 9.

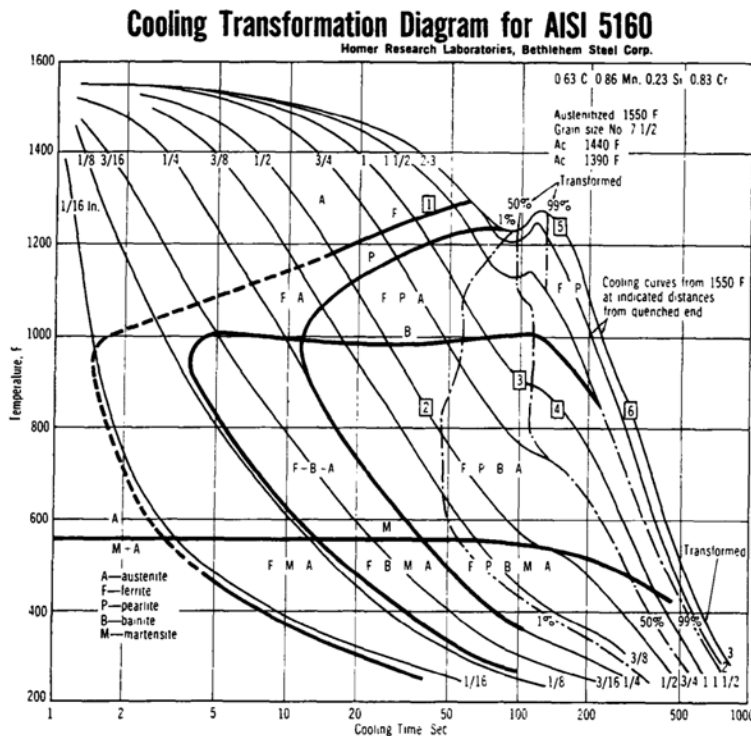

Figure 9: Cooling transformation diagram for AISI 5160 (AISI 5160 (High Strength Machinery Steel), 1952)

To compare the two spring steels, AISI 1095 actually shares its modulus of elasticity and its shear modulus with the AISI 5160. That modulus of elasticity is 205 GPa, and that shear modulus is 80 GPa. However, the 1095 steel can withstand a lot more stress before reaching its elastic limit, with a yield strength of 525 MPa compared to only 275 MPa for AISI 5160.

2.4 Stress, Strain, and Fatigue

The spring has forces applied to it constantly, therefore stress is distributed as a varying function throughout the part. Every portion of the material can experience different stresses at the same time, thereby stress must be examined as “acting on vanishingly small elements within the part” (Norton, 2011). Strain is the change in length per unit length in a material, so it’s a way of determining deformation or displacement in a material as a result of applied stresses (Norton, 2011).

We researched failure by fatigue because the springs underwent repeated loads from whammy bar use over a period of time before failure, so analyzing the fractures as a result of fatigue failure seemed appropriate given the cyclical nature of the loading. We also researched treatments we could apply to the spring to help prevent fatigue failure.

Fatigue fractures typically start at the surface, at a defect in the material that may even be present from manufacturing. Cracks can form in spring steels such as the material our spring is made from because metals are not homogenous at the microscopic scale, so there are some regions of stress concentration which are called notches. The stress will oscillate at these notches as the whammy bar is used, causing local yielding to occur. Local yielding leads to slip bands, regions of intense deformation due to shear, forming along the crystal boundary in the material. The slip bands eventually come together as microscopic cracks. Cracks create stress concentrations larger than that of the notch, and a plastic zone forms at the crack tips when it’s opened by a tensile stress. Every time the crack is opened it grows a small amount; therefore, crack growth is due to compressive stress. Crack growth occurs along planes normal to tensile or compressive stress which is consistent with how the springs that we have were broken. The fracture surface on our broken springs is in a straight line along the spring normal to the compressive forces on the spring from using the whammy bar (Norton, 2011).

The cracks continue to grow under cyclical stress until the stress intensity factor at the crack tip is equal to the material's fracture toughness. When this point is reached, failure will occur instantaneously on the next tensile stress-cycle. The stress intensity factor is equal to the square root of the nominal stress, and the crack length (Norton, 2011).

Cracks grow much more rapidly in a brittle material than a ductile material because brittle materials have a higher notch sensitivity, or sensitivity to stress concentrations. To make our springs less susceptible to fracture we investigated different treatments that incorporate residual compressive stresses into the material (Norton, 2011).

Residual stress relates to stresses that are incorporated into an unloaded part, usually as a result from manufacturing processes. Any treatment that creates localized strain above the yield point will leave stress in the part. There are several methods for introducing compressive residual stress into parts such as thermal treatments, surface treatments and mechanical prestressing treatments. Treatments create either compressive stresses or tensile stresses at either the surface or core of the material, and these residual stresses are meant to counteract the loading that will be

applied to the part. Residual stresses are tailored to create positive effects on the strength of the material while not creating any negative effects. When done properly residual stresses can greatly improve the fatigue life of a part, especially for high-yield strength materials such as our spring steel (Norton, 2011).

2.5 Buckling Analysis

Buckling is a mode of material failure in which the member reaches a critical compressive force, causing it to suddenly collapse under the stress. A diagram of a beam buckling looks like the image shown in Figure 10. The critical load required for the beam to buckle is dependent upon material properties and geometry of the member. The equation for buckling is $F = \frac{\pi^2 EI}{KL^2}$, where F = max force, E = modulus of elasticity, I = minimum value of the area moment of inertia, L = length of member, and K = length factor. The length factor is dependent on if and how each end of the member is attached to a fixed structure. Buckling is commonly found in beams that are long and thin, as both of those conditions lower the force required in order for the object to buckle.

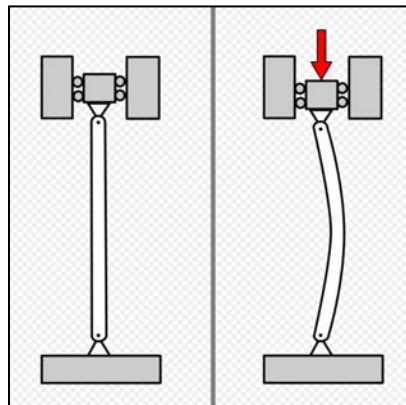

Figure 10: Buckling in a Beam

2.6 Ansys Workbench

ANSYS is a software used to simulate models and their function from Computer Aided Design (CAD). This software is used to solve problems in “static/dynamic, structural analysis, heat transfer, fluid problems, acoustic and electromagnetic problems” (Nakasone). This way an engineer can explore and predict any errors that can occur before it is readily produced for the real world, saving the need to waste material and money to perfect a design to its best quality. It

is a “general-purpose, finite-element modeling package for numerically solving a wide variety of mechanical problems” (Nakasone).

2.7 Scanning Electron Microscope

A scanning electron microscope (SEM) is used to generate high resolution images of shapes of objects. The SEM uses a high-energy electron beam to get signals from the surface of the object. These signals can inform the user on the topography of the surface, chemical composition, and crystalline structure of the material. Data is collected from a small section of surface area on the object. From the data, a two-dimensional image is created to show variations in the three properties mentioned (Swapp, 2017). These two-dimensional images are able to show magnified images of fracture surfaces to indicate the kind of fracture present in that area. Figure 11 below is an example of a ductile fracture, where Figure 12 is an example of brittle fracture.

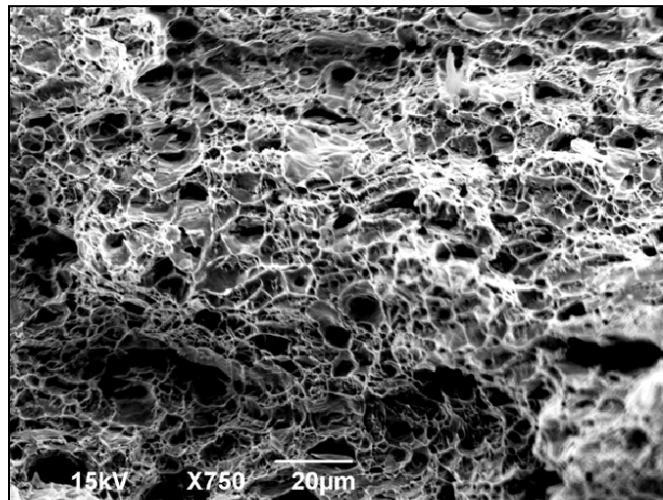

Figure 11: Example of ductile fracture under SEM (Ziemian, Constance & Sharma, Mala & Whaley, Donald, 2012)

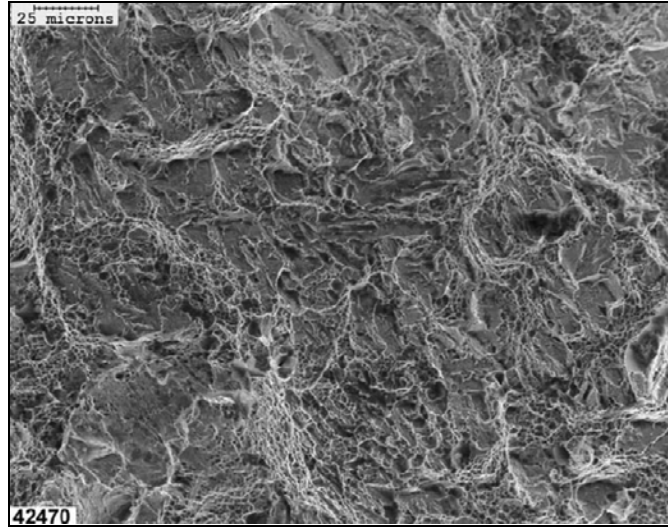

Figure 12: Example of brittle fracture under SEM (Bahrami, Amir & Zhang, Yanhui & PeterTubby, 2015)

The SEM is capable of much more than an optical stereo microscope. It is also capable of Energy-Dispersive X-Ray Spectroscopy (EDS). To do this, the SEM bombards the surface with a high-energy electron beam. This causes emissions, including X-rays for the EDS detector to collect. The EDS detector holds a crystal that absorbs the energy from the X-rays. Through ionization the crystal becomes conductive and holds a proportionate charge to the element represented. The detector can then separate the X-rays of elements into an energy spectrum and use software to determine an abundance of a specified element (Goodge, 2017).

2.8 Hardness Testing

Hardness testing is used to test the hardness of a material. Material hardness is defined as the resistance to indentation (Newage 1). This is done by pressing an indenter of a fixed load into a surface. The hardness of the material is then measured by the depth and radius of the newly-formed hole. It is imperative that the material the indenter is made out of is stronger than everything that it is testing because if that is not the case, the indenter itself will get deformed instead of the surface that testing was intended for. That is why many hardness testers have a diamond indenter, as it is the hardest sourceable material in the world. There are also different types of indenters. Each indenter is shaped differently as you can see in Figure 13.







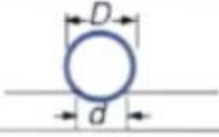
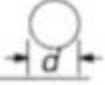

Hardness test Indenter Load	Shape of indentation	
	Side view	Top view
Brinell 1-cm steel or WC ball 500 – 3000kg		
Vickers Diamond pyramid 1 – 120kg		
Knoop Diamond pyramid 26g – 5kg		
Rockwell A, C, D Diamond cone 60, 150, 100 kg		
Rockwell B, F, G 1/16-in.-diameter steel ball 100, 60, 150 kg		
Rockwell E 1/8-in.-diameter steel ball 100 kg		

Figure 13: Hardness Testing Indenters (Ohring, 2007)

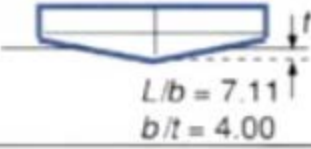
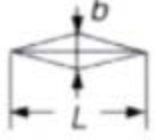
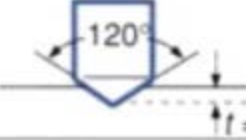
3.0 Methodology

3.1 Objective 1: Identify Mode of Failure

In order to successfully manufacture an improved spring, we were first required to identify the mode of failure of the original spring. To do this, several different elements were investigated. The first avenue pursued was transient structural analysis of the original spring using ANSYS Workbench. Fracture surface analysis was done using the scanning electron microscope. It was attempted to determine the force applied to the spring using force sensors. Hardness testing was also done to determine the method in which the springs were

manufactured. Finally, a rig was built to recreate the force exerted on the spring to better view the motion of the spring in use.

3.1.1 3D Parts, Assemblies, and Ansys Analysis

In order to replicate the flat spring we needed to know how much material we needed to use. The SolidWorks model (Figures 14 and 15) given was unable to produce a flat model, we opted to use the spring's blueprint which gave us an approximate total length of materials needed in inches.

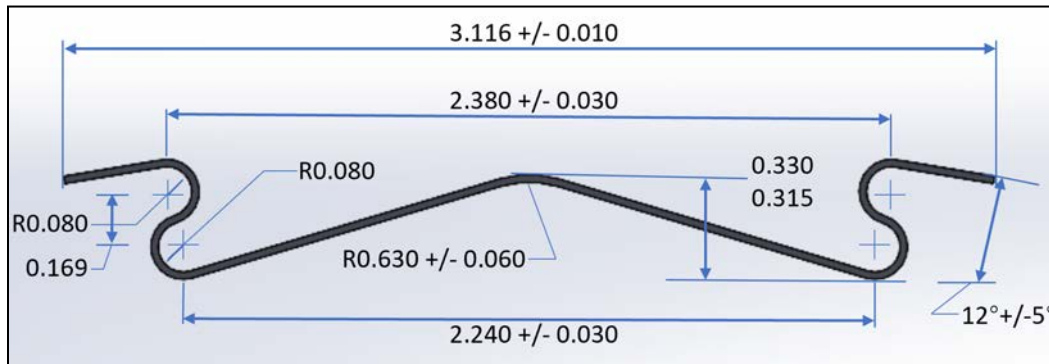

Figure 14: SolidWorks model of 9 gauge flat spring with dimensions

9 Gauge Flat Spring:

End lengths:

$$3.116 - 2.38 = 0.736$$

$$0.736 = \text{Total for end lengths}$$

$$0.736 \div 2 = 0.368$$

$$0.368 = \text{Length end}$$

Arc length for one bend:

$$\frac{\theta}{360} \times 2\pi r$$

$$\frac{90}{360} \times 2\pi(0.08) = 0.1257$$

$$0.1257 \times 4 = 0.5028$$

$$0.5028 = \text{Total arc length for all four bends}$$

Length between bends:

$$2.38 - 2.24 = 0.14$$

$$0.14 = \text{Total between bends}$$

$$0.07 = \text{Between bends (x-adjacent)}$$

$$0.169 = \text{Height between bends (y-opposite)}$$

$$\sqrt{(0.07^2) + (0.169^2)} = 0.183$$

$$0.183 \times 2 = 0.366$$

0.366 = Total length between bends

Middle length:

$$0.33 = \text{Height (y-opposite)}$$

$$2.24 \div 2 = 1.12$$

1.12 = length across one side (x-adjacent)

$$\sqrt{(0.33^2) + (1.12^2)} = 1.17 \text{ (Length of flat plane - one side)}$$

$$1.17 \times 2 = 2.34$$

$$\frac{90}{360} \times 2\pi(0.63) = 0.989$$

0.989 = Arc length of center bend

$$2.34 + 0.989 = 3.329$$

3.329 = Total middle length

Total length:

$$0.736 + 0.503 + 0.366 + 3.329$$

4.934 = Total length for 9 gauge flat spring

Angle of center bend:

$$\cos(\theta) = \frac{1.12}{1.17}$$

$$\theta = 16.81^\circ$$

Following that a right triangle has a total degree of 180.

$$180 - (16.81 + 90) = 73.19$$

$$73.19 \times 2 = 146.38$$

146.38° = Total degree of center bend

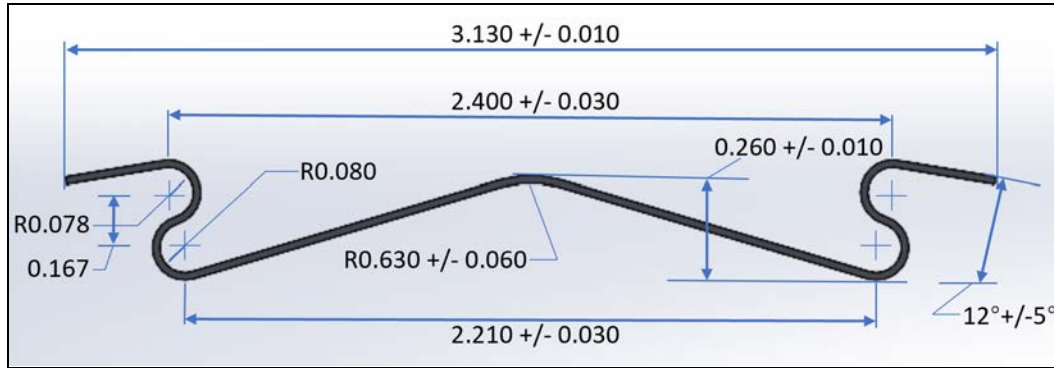

Figure 15: SolidWorks model of 10 gauge flat spring with dimensions

10 Gauge Flat Spring:

End lengths:

$$3.13 - 2.4 = 1.03$$

$$1.03 = \text{Total for end lengths}$$

$$1.03 \div 2 = 0.515$$

$$0.515 = \text{Length end}$$

Arc length for one bend ($r = 0.078$):

$$\frac{\theta}{360} \times 2\pi r$$

$$\frac{90}{360} \times 2\pi(0.078) = 0.123$$

$$0.123 \times 2 = 0.246$$

$$0.246 = \text{Total arc length for all two bends}$$

Arc length for one bend ($r = 0.08$):

$$\frac{\theta}{360} \times 2\pi r$$

$$\frac{90}{360} \times 2\pi(0.08) = 0.126$$

$$0.126 \times 2 = 0.252$$

$$0.252 = \text{Total arc length for all two bends}$$

Length between bends:

$$2.4 - 2.21 = 0.19$$

$$0.19 \div 2 = 0.095$$

$$0.095 = \text{Between bends (x-adjacent)}$$

$$0.169 = \text{Height between bends (y-opposite)}$$

$$\sqrt{(0.095^2) + (0.169^2)} = 0.1939$$

$$0.1939 \times 2 = 0.388$$

$$0.388 = \text{Total length between bends}$$

Middle length:

$$0.26 = \text{Height (y-opposite)}$$

$$2.21 \div 2 = 1.105$$

$$1.105 = \text{length across one side (x-adjacent)}$$

$$\sqrt{(0.26^2) + (1.105^2)} = 1.135 \text{ (Length of flat plane - one side)}$$

$$1.135 \times 2 = 2.27$$

$$\frac{90}{360} \times 2\pi(0.63) = 0.989$$

$$0.989 = \text{Arc length of center bend}$$

$$2.27 + 0.989 = 3.359$$

$$3.359 = \text{Total middle length}$$

Total length:

$$1.03 + 0.246 + 0.252 + 0.388 + 3.359$$

$$5.275\text{in} = \text{Total length for 10 gauge flat spring}$$

Angle of center bend:

$$\cos(\theta) = \frac{1.105}{1.135}$$

$$\theta = 13.2^\circ$$

Following that a right triangle has a total degree of 180.

$$180 - (13.2 + 90) = 76.8$$

$$76.8 \times 2 = 153.6$$

$$153.6^\circ = \text{Total degree of center bend}$$

The calculations above display that the 9 gauge flat spring has a total length of 4.934in with a center bend of 146.38° and the 10 gauge flat spring has a total length of 5.275in with a center bend of 153.6°.

When using ANSYS, our first goal was to create a transient structural analysis of the spring in the flat position. This is not how the spring lays when in the guitar, but this analysis provides information of general weaknesses of the design. To complete this transient analysis, a mesh of refinement 3 was used. This was important to get more detailed results for the high stress regions of the spring. In this structural analysis we calculated equivalent stress and strain, normal stress, shear stress, and deformation. It was found that the high stress concentrations were located at the peaks of the flat spring (Figure 16), which means that the spring should break along this area, however, our springs most often did not break at these locations. Instead, they broke mostly along the middle of the flat planes.

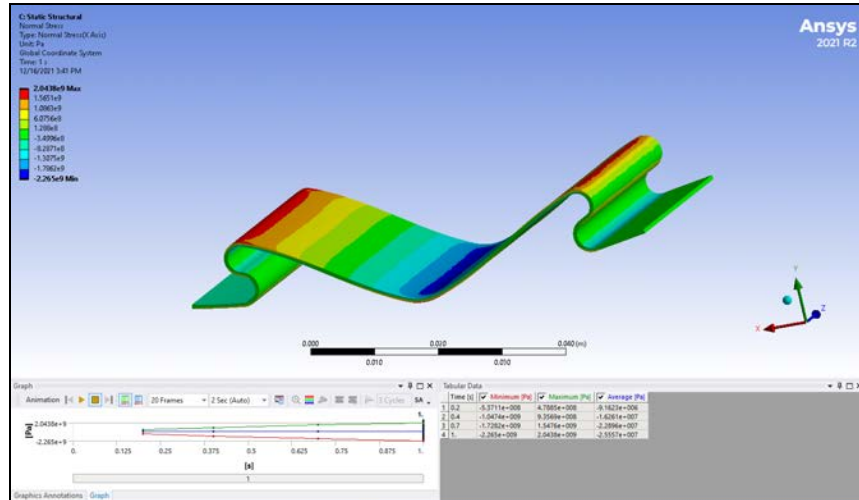

Figure 16: Ansys model for stress analysis

Calculations for buckling were done in ANSYS as well as by hand. In ANSYS the springs buckled at a lower than normal value. This value was 1.74 times the pre-load stress, which we set to 375 N, making the total buckling force required 652.5 N. With the results we received from the hardness tester, which is explained in detail in the upcoming section, and the spring being long, thin, with relatively low modulus of elasticity, this all presented the prerequisites for the spring to buckle. In Figure 17, the hand calculations for buckling used the statistics for AISI 1095 steel, cold drawn, and spheroidized annealed. The values used in the calculation were the modulus of elasticity, $(E) = 205GPa$, length of member $(L) = 0.06045m$, length factor $(K) = 0.7m$ and the minimum value of the area moment of inertia (I) . We found the force to be $1.130 \times 10^{15} N/m * (I)$. These results indicated a cause for failure. However, we cannot yet conclude that the spring did fail because of buckling due to the motion of the spring and because the ANSYS calculations were done on a flat spring with different loading conditions than were in the actual guitar.

Buckling Calculation

$$F = \frac{\pi^2 EI}{(KL)^2} = \frac{\pi^2 (205 \text{ GPa}) (I)}{(0.7(0.06045 \text{ m}))^2} \quad \rightarrow \quad 205 \text{ GPa} = 205 \times 10^9 \text{ N/m}^2$$

↑
gauge l

$$F = \frac{\pi^2 (205 \times 10^9 \text{ N/m}^2) I}{(0.7(0.06045 \text{ m}))^2} = \frac{2.023 \times 10^{12} \text{ N/m}^2 (I)}{0.00179 \text{ m}^2}$$

$$F = 1.130 \times 10^{15} \frac{\text{N}}{\text{m}^4} (I)$$

Figure 17: Buckling Hand Calculations

Using the SolidWorks model from the previous groups, an assembly using the T-bar and 3 ridge plate was designed in SolidWorks to best replicate the conditions in the guitar and the forces applied to the spring. We used this geometry to create a new Ansys structural analysis to find high stress regions in the spring as shown in Figure 18. Unfortunately, we were unable to get any results due to unforeseen technical complications with the software giving us no conclusive results.

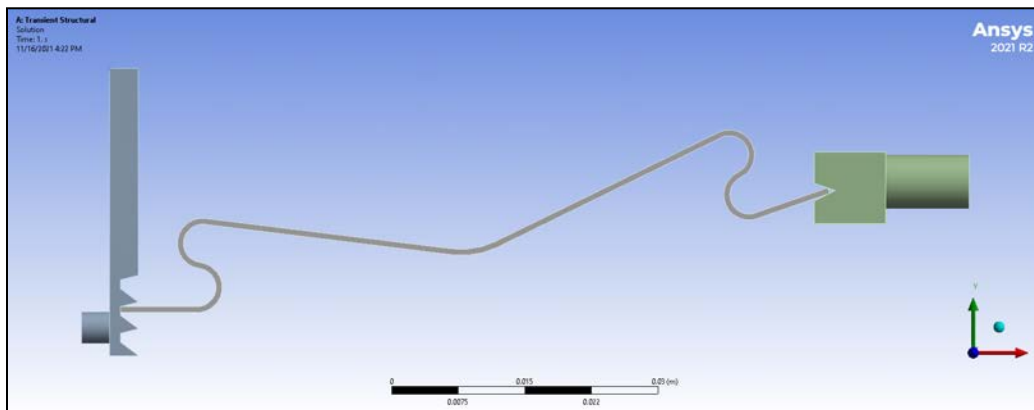

Figure 18: Image of Ansys file with T-bar and three ridge plate assembly

3.1.2 Fracture Surface Analysis

Along with this analysis, we utilized both a stereo microscope and a scanning electron microscope to examine the fracture surface shown in Figure 19. Here, we attempted to identify possible indicators of fatigue failure as well as pinpoint the origin of the fracture. The scanning electron microscope was also used to execute a material analysis of the fracture surface, as well

as inclusions within the spring. We were unable to identify the origin of the fracture, or any signs of fatigue. Images of the fracture surface are shown in Figures 19 and 20. The fracture surface indicated brittle fracture rather than fatigue.

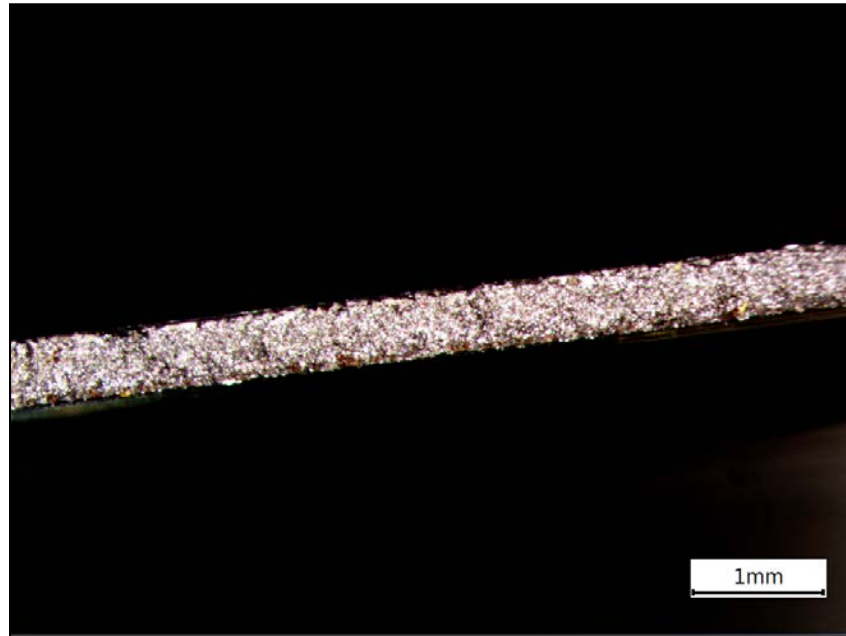

Figure 19: Image of fracture surface from optical stereo microscope

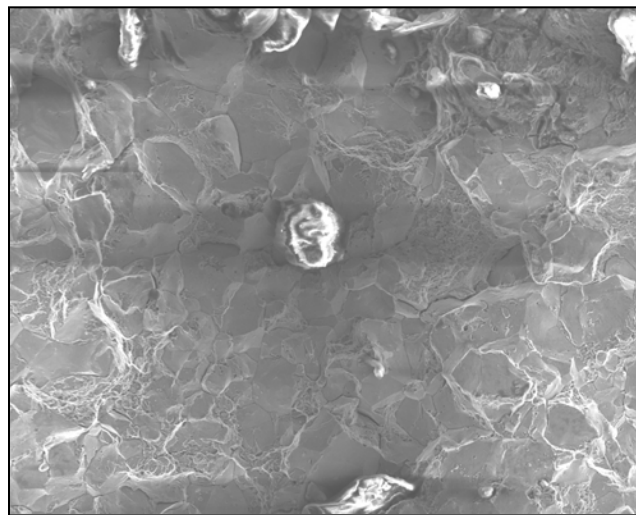

Figure 20: Image of fracture surface showing inclusion and brittle fracture

3.1.3 Force Sensor Analysis

We attempted to gather data on how much force was applied to the spring when the whammy bar was used by taping a force-sensitive resistor from Sparkfun to the flat surface of the spring closer to the step-stop as that side of the spring experiences more deformation. Our

resistor was plugged into rows twenty-one and twenty-two in the circuit shown in Figure 21. The additional resistor used in this circuit is a ten kilo-ohm resistor which was informed by the circuit diagram in the documentation for the part. As force was applied by the whammy bar the force sensor flexed causing a change in resistance which was read with an Arduino board. The code in the Arduino IDE used for reading resistance values from the force sensor is in Figure 22. The corresponding force values were determined by a force curve that graphed force vs. resistance. The force curve that correlated with the specific part #SEN-09673 was available from the company that produced the force sensitive resistor, Sparkfun. This force sensitive resistor maxed out at 10kg during testing, and we were unable to find a different force sensor that both physically fit on the spring and had the range to read the force applied to the spring, so we developed a different method to find the force on the spring.

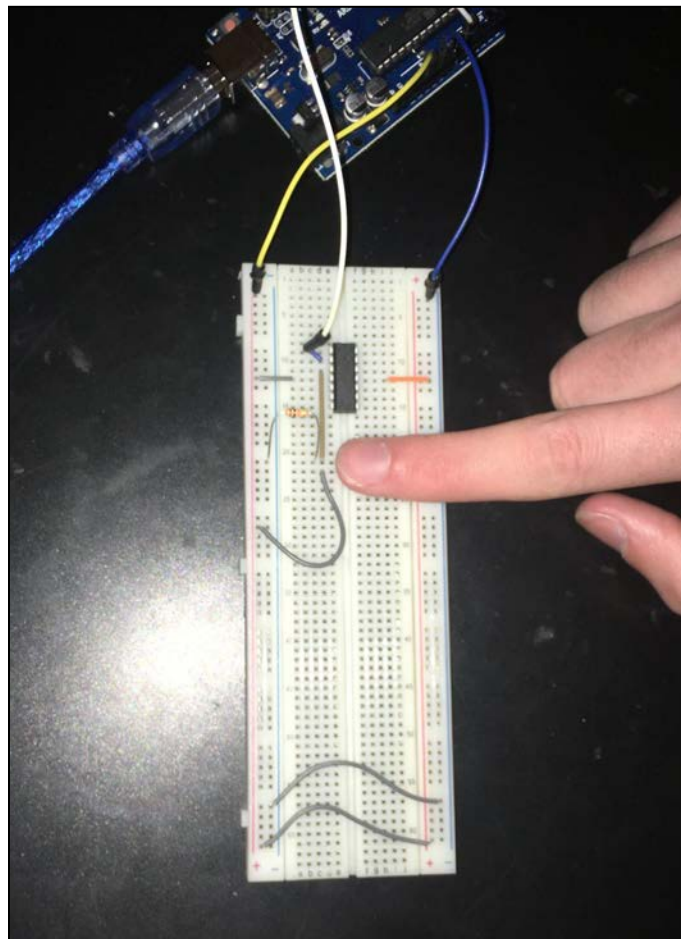

Figure 21: Circuit used for force-sensitive resistor

```
int Pin=A0;
int Force=0;
void setup() {
  Serial.begin(9600);
}

void loop() {
  Force = analogRead(Pin);
  Serial.println(Force);
  delay(10);
}
```

Figure 22: Code used in Arduino IDE for the force sensor

3.1.6 Survey

One major component of our research was the list of questions compiled below. The questions were sent out in the form of a survey to Parker Fly guitarists through Professor Manzo's forum FlyClone.com. We submitted an application to the IRB so they were able to consider the ethics of this survey, and since we have received the all clear from them, we sent out the survey and gained considerable knowledge from Parker Fly guitarists on how their springs broke.

- 1) Have you broken a spring?
 - a) Yes
 - b) No
- 2) How aggressive are you with the Whammy bar?
 - a) Don't Use
 - b) Gentle
 - c) Moderate, more on the gentle side
 - d) Moderate
 - e) Moderate, more on the aggressive side
 - f) Most Aggressive
- 3) How frequently do you use the Whammy Bar when you play your Parker Fly?
 - a) Almost never
 - b) Very rarely
 - c) Occasionally
 - d) Usually
 - e) Almost always
- 4) How often do you play your Parker Fly?
 - a) Once every few months
 - b) About once a month
 - c) About once a week
 - d) Multiple times a week
 - e) About once a day
- 5) Where did you get your spring?
 - a) Came installed in the instrument when I purchased it new

- b) Came installed in the instrument when I purchased it used
 - c) Came in the case when I purchased the instrument new
 - d) Came in the case when I purchased the instrument used
 - e) I bought this spring from a third-party (eBay, Reverb, etc.)
 - f) Other
- 6) What were you doing when the spring broke?
- a) I was using the whammy bar when it broke
 - b) I was playing but not using the whammy bar when it broke
 - c) I was changing strings or doing some other service when it broke
 - d) It was broken one day when I went to play it
 - e) Open response for additional comment
- 7) Where did your spring break? (Select all that apply)
- a) 1
 - b) 2
 - c) 3
 - d) 4
 - e) 5
 - f) Other: Open response

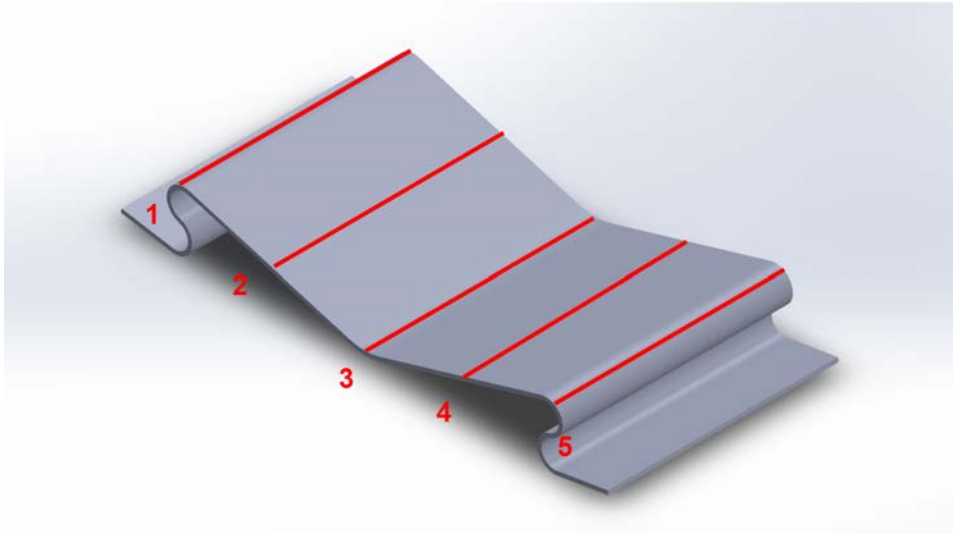

- 8) What gauge springs did you use?
- a) 8.5
 - b) 9
 - c) 10
 - d) 11
 - e) 12
 - f) Unknown
- 9) Which slot was the spring in when it broke (upper, middle, lower)
- a) 1
 - b) 2
 - c) 3
 - d) Unsure

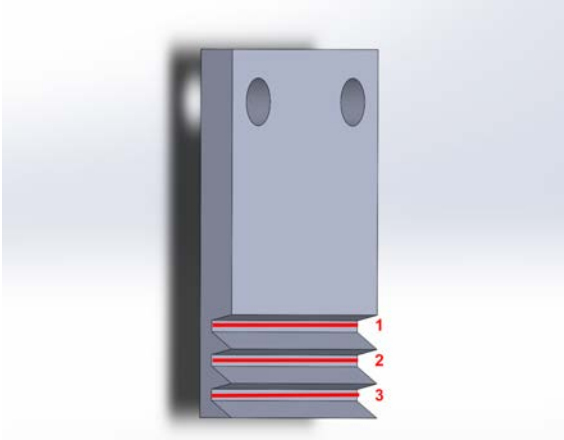

- 10) Do you usually push the whammy bar down or pull it up?
 - a) Push it down
 - b) Pull it up
- 11) Please enter your email address if you'd be willing to briefly discuss the circumstances around your spring break via Zoom. (optional)

From the survey we gathered a total of 13 responses; four of them said they had broken a spring, and all of them were able to give us a better understanding of the circumstances surrounding their spring breaks. The summary of the survey results are all shown in the pie charts below.

Have you broken a spring?

13 responses

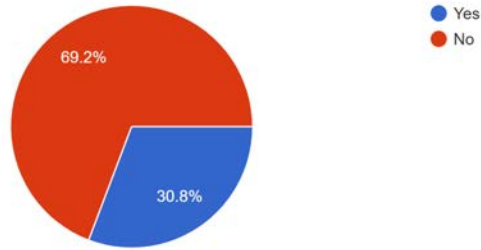

How aggressive are you with the Whammy bar?

13 responses

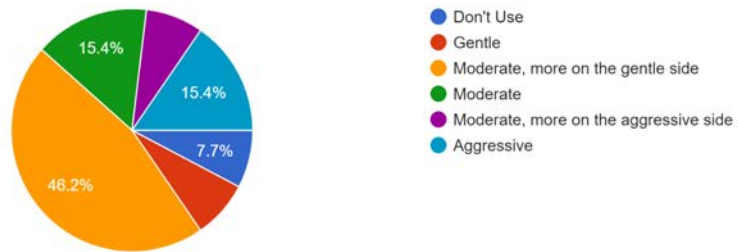

How frequently do you use the Whammy Bar when you play your Parker Fly?

13 responses

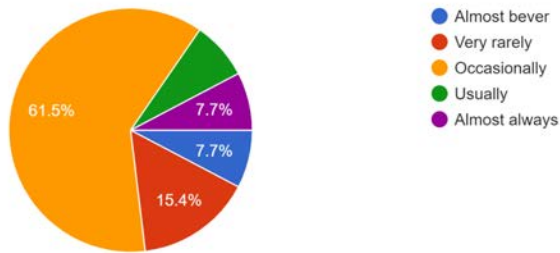

How often do you play your Parker Fly?

13 responses

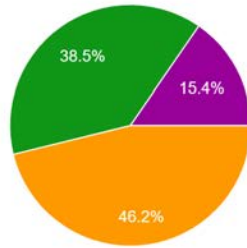

- Once every few months
- About once a month
- About once a week
- Multiple times a week
- About once a day

Where did you get your spring?

13 responses

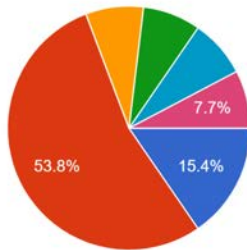

- Came installed in the instrument when I purchased it new
- Came installed in the instrument when I purchased it used
- Came in the case when I purchased the instrument new
- Came in the case when I purchased th...
- I bought this spring from a third-party (...)
- Multiple Parkers fit all the above
- I've got LOADS of springs, been colle...

What were you doing when the spring broke?

8 responses



- I was using the whammy bar when it broke
- I was playing but not using the wham...
- I was changing strings or doing some...
- It was broken one day when I went to...
- didn't break; I don't use the whammy f...
- hasnt broke yet
- Haven't broken a spring. Fingers cros...
- I had not played the Fly for at least a...
- Not broken

Where did your spring break? (Select all that apply) (see image above)

8 responses

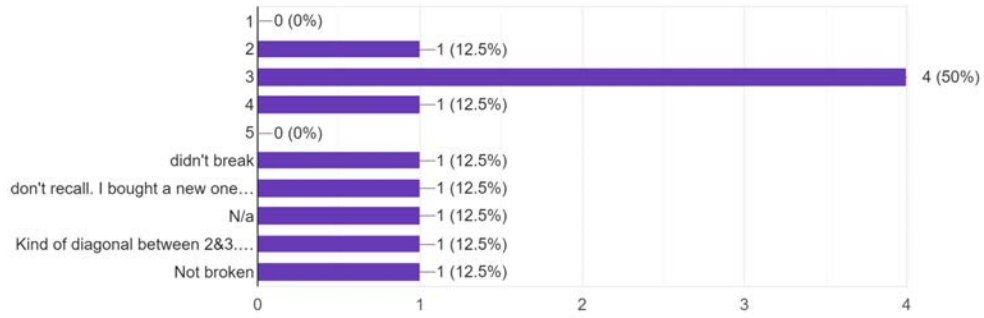

What gauge springs did you use?

11 responses

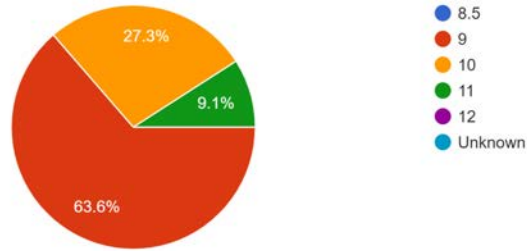

Which slot was the spring in when it broke (upper, middle, lower) (see image above)

9 responses

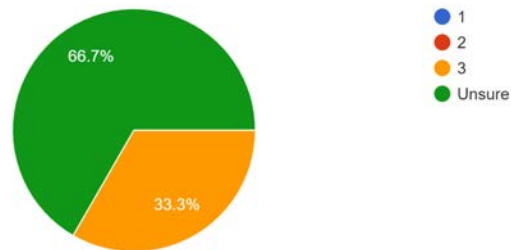

Do you usually push the whammy bar down or pull it up?
10 responses

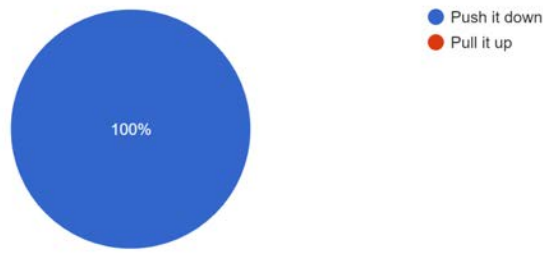

The table below shows the individual responses from each guitarist who had previously broken a spring. These responses revealed a couple similarities between the broken springs. Despite some similarities, not every spring break happened under the same conditions.

The first, third, and fourth guitarist to break a spring that responded to the survey recorded very similar answers. They all use the whammy bar on occasion, without too much force, and play their Parker Flys once or twice a week. Also, they all got their springs used, which led us to believe that the springs were manufactured poorly, material weaknesses had already begun to form, or some sort of flaw had already been present in the spring before the guitarists even began to use them.

The second guitarist has many springs that he purchased new, however he plays his Parker Fly very frequently and uses the whammy bar aggressively, which led us to believe one time the spring was just put under too much stress and snapped. However, as we know from the hardness testing we performed, even the springs that were manufactured were much too hard. As a result, they were subject to brittle fracture, and it appears the same thing had occurred.

Question	Parker Fly Guitarist 1	Parker Fly Guitarist 2	Parker Fly Guitarist 3	Parker Fly Guitarist 4
Have you broken a spring?	Yes	Yes	Yes	Yes
How aggressive are you with the Whammy bar?	Moderate, more on the gentle side	Aggressive	Moderate, more on the gentle side	Moderate, more on the gentle side

How frequently do you use the Whammy Bar when you play your Parker Fly?	Occasionally	Usually	Occasionally	Occasionally
How often do you play your Parker Fly?	Multiple times a week	About once a day	About once a week	About once a week
Where did you get your spring?	Came in the case when I purchased the instrument used	Came installed in the instrument when I purchased it new	Came installed in the instrument when I purchased it used	Came installed in the instrument when I purchased it used
What were you doing when the spring broke?	I was changing strings or doing some other service when it broke	I was using the whammy bar when it broke	It was broken one day when I went to play it	I was using the whammy bar when it broke
Where did your spring break?	3&4	Diagonal between 2&3	3	Unsure
What gauge springs did you use?	10	9	9	9
Which slot was the spring in when it broke?	3 (bottom)	3 (bottom)	Unsure	Unsure
Do you usually push the whammy bar down or pull it up?	Push it down	Push it down	Push it down	Push it down

3.2 Objective 2: Process Design

3.2.1 Rig Manufacturing

In order to get a better understanding of the motion of the spring while in the guitar, and also test some potential relocations of the T-bar that holds the back of the spring in the guitar. One of the challenges for identifying a mode of failure for the spring is accounting for the angle at which the spring is fixed when inside the guitar. To get a better view of how the spring moves when the vibrato arm is applied a rig was built that replicates the conditions of the spring inside the guitar. First, a prototype was built out of wood to simulate the motion of the spring without using the force of the strings (Figure 23). This prototype had a few major problems. The first problem was that it failed to duplicate the 2.75° angle of the bridge. The second problem was that, using wood tools, we could not get the accuracy of the dimensions that we would have liked. Despite these problems, it is still a useful tool in demonstrating and understanding the basic mechanism inside of the guitar.



Figure 23: First iteration of rig made of wood

The second iteration was machined out of aluminum. This rig was built to attach to an already existing mechanism shown in Figure 24 that is strung like a guitar, to account for the force exerted on the spring by the strings of the guitar. Aluminum was chosen because it would not split under the force of the strings like wood might. The two problems in the prototype were able to be addressed in this iteration. Once the rig is attached to the mechanism, the whammy bar is able to be pushed and pulled like it would be used on the guitar. To test whether the spring “floats” to stay in tune, a pin can be placed to fix the bridge while tuning. When the pin is removed it will allow the bridge to float, and if the guitar is still in tune, we can determine that our spring does float adequately. It also is open on one side to allow us to view the behavior of

the spring while using the whammy bar. The behavior we hope to observe is how much the spring will deform as well as where the largest amount of deformation occurs.



Figure 24: Mechanism previously assembled which will be utilized to use the Parker Fly rig described above (Manzo, 2020)

3.2.2 Heat Treatment and Hardness Testing

A helpful component of our research was the hardness testing Professor Levey performed with us under the supervision of the lab manager in Washburn. We tested using the standard Vickers indenter (Figure 25), and figured out that the spring was 58.85 HRC on average. All of the values obtained from the hardness testing are listed in Figure 26 below. The standard hardness for the spring should have been 48.0-52.0 HRC if it were a 9-gauge and 50.0-54.0 HRC if it were a 10-gauge. This is important because the harder the material, the more brittle it becomes, and the extreme hardness of the old springs meant they snapped easily under stress. Also, the break along the surface looked like a brittle fracture, and this hardness testing supplements that conclusion.

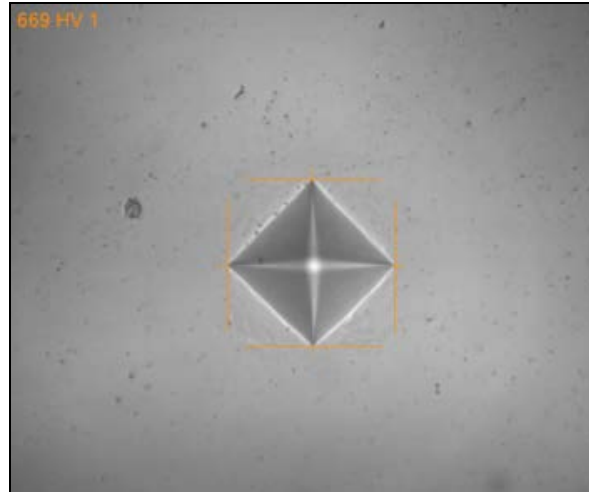

Figure 25: Hardness Testing using a Vickers indenter

Point	Hardness	Converted	Diagonal X	Diagonal Y	Comments	Magnification	Indenter
1	672 HV 1	58.90 HRC	51.9 μm	53.2 μm		100X	Vickers
2	668 HV 1	58.70 HRC	52.7 μm	52.7 μm		100X	Vickers
3	669 HV 1	58.80 HRC	52.5 μm	52.8 μm		100X	Vickers
4	672 HV 1	58.90 HRC	52.4 μm	52.7 μm		100X	Vickers
5	672 HV 1	58.90 HRC	52.6 μm	52.5 μm		100X	Vickers
6	678 HV 1	59.20 HRC	52.6 μm	52.0 μm		100X	Vickers
7	669 HV 1	58.80 HRC	52.8 μm	52.4 μm		100X	Vickers
8	665 HV 1	58.60 HRC	52.8 μm	52.7 μm		100X	Vickers

Figure 26: Hardness Testing Data

Our second objective, once a failure mode was identified, was to design a process to manufacture the springs correctly. Using Granta Edupack (*Ansys (CES) Granta Edupack*), a materials database in ANSYS, we compared the desired hardness with the original design requirements of the spring. As previously stated, the results from the hardness testing for the original spring was harder than said to be due to the heat treatment process. We tested four cut out pieces ($\frac{1}{2}$ inch x $\frac{1}{2}$ inch) from the 1095 annealed spring steel sheet metal to figure out what process of heat treatment caused the metal to be harder, therefore allowing us to identify a point of failure. Four pieces were heat treated to 850°C . Ten minutes later, two pieces were put into a water quench and the other two were placed into an oil quench, both at room temperature. Then one from each quenching source was placed into an oven of 205°C and 315°C for an hour. From there, the pieces were taken out and air cooled until they were able to be touched.

Next, we took the four heat treated pieces of metal and a cut of the 1095 as-annealed spring steel, and mounted each in resin. We took each mounting and polished them in preparation for hardness testing. After we tested the hardness of only the oil quenched springs,

we found it to be still too hard. We took the results to create a linear forecast and a new plan was formulated to temper the finished springs at 350°C and 375°C after oil quenching (Figure 27).

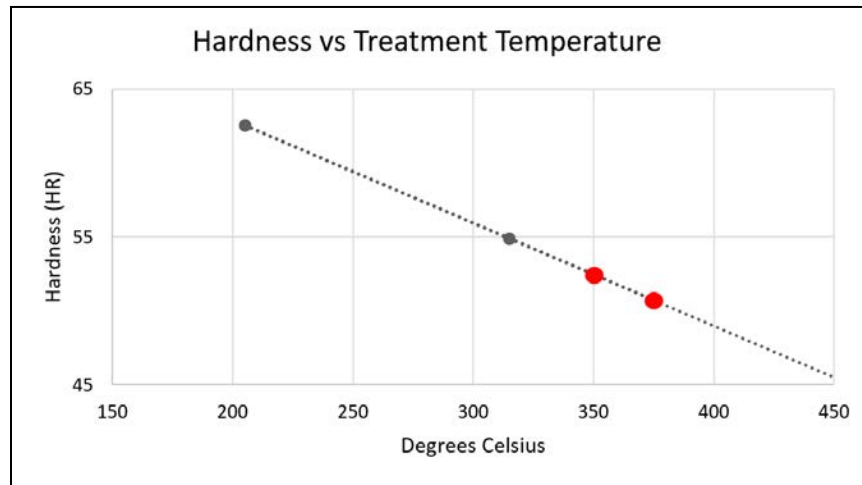

Figure 27: Hardness vs. Heat Treatment Temperature Graph

3.3 Objective 3: Manufacturing Processes

We used the laboratories in Washburn Shops to implement our design into a physical spring through the use of many different tools. To shape the spring we first believed it would be best to use the tube bender with dies to bend the sheet metal around. Our first idea on how to make the dies was to 3-D print them, however, after discussing with our advisors we decided it was best not to use this method as the force necessary to bend 1095 steel would be too much for any available filament in the WPI Prototyping Lab. We then thought about machining tool steel for our dies using the mills available in Washburn Shops, but if we were to form the spring using metal dies, concerns arose as to how we would use the tube bender to form the tight S-bends of the original spring. We could not do both bends in the S because the previously bent metal would get in the way when we went to do the second bend. Not to mention, the radius of the dies were far too large for the small radius of the edge bends in the springs, and the dies did not even extend an inch out of the surface. Since our sheet metal was 1.5 inches wide, it was not able to bend the full surface of our sheet metal, leaving slight deformations after every bend. Because of all these obstacles, we designed a part to fit the much larger brake bender, thanks to the suggestion of the Washburn lab manager, Torbjorn Bergstrom. The SolidWorks model of this part is shown below in Figure 28.

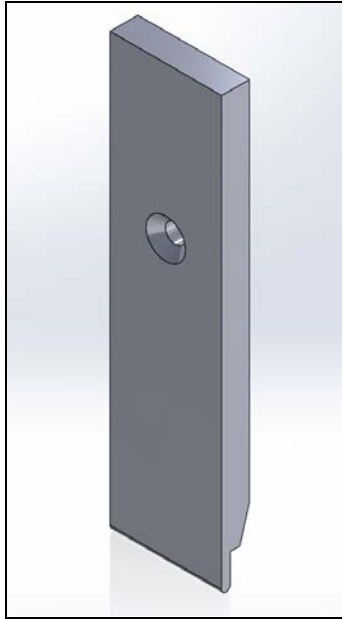

Figure 28: Brake Bender die in SolidWorks

The idea behind this part is the bottom radius, which is 2.00 mm, unlike the other parts in the brake bender which bend the metal around a sharp edge. This will help us get the exact end radius on the spring, and the cavity behind the edge we are bending around will allow for maximum rotation as we are bending.

We decided to make the flat spring out of 1095 spring steel. We ordered this material annealed from McMaster-Carr. The selected dimensions were 8" x 12", 0.025" +/- 0.002" thickness and 0.02" +/- 0.002". This type of material was used in the production of the original spring. Annealed 1095 Spring Steel has a yield strength of 60,000 psi, it has a softened temper that way it can be easily shaped before heat treatment. 1095 Steel contains a high carbon amount allowing for better wear resistance. This type of material is ideal for our project due to it being under constant stress and allowing for better spring action.

The machine we used to cut the annealed spring steel sheet metal was the Peck Stow & Wilcox USA hydraulic shearing machine, as seen in Figure 29. The maximum thickness the machine can cut for steel is 1/16" and for aluminum 1/8". The limitations of the machine come with an approximate desired length and/or width of cut rather than an exact length and/or width of cut due to limited visibility and movement while shearing.

We marked the sheet metal to its desired width, as seen in Figure 30, then sheared the sheet metal. Figure 31, displays all the tools we used and the pieces we cut. The next tool we used was a sheet metal sander. The sheet metal sander is a relatively simple machine, a rotating wheel spins at over 2000 rpm, and we used that wheel to grind away any burrs and sharp edges that were left by the shearing machine. A picture of it can be seen in Figure 32.



Figure 29: Image of the Peck, Stow & Wilcox hydraulic shearing machine



Figure 30: Sheet metal marked to desired width for shearing

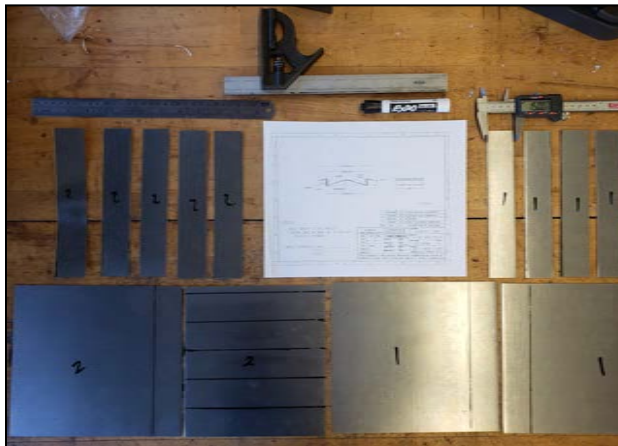

Figure 31: Display of equipment used and the sheared pieces of sheet metal



Figure 32: Image of sheet metal sander

The third tool we used was the brake bender. The brake bender is what we used to do the majority of the spring bending (Figure 33). It is a large machine that consists of a flat surface and a rotatable surface. The metal is positioned on both parts, at the desired bending location, and then clamped down to the flat surface. A lever arm is used to pull the rotating surface up, effectively bending the metal around an edge. The edge that is made to go with the bender naturally was far too sharp, so we used the die that we manufactured in the brake bender. The final tool was a tube bender, which could only be used to do the final center bend. The tube bender is operated manually (Figure 34). A lever arm bends the metal in a circular shape around a die. The radius of the bend is determined by the thickness of the die.



Figure 33: Image of Tennsmith Brake Bender



Figure 34: Image of Tube Bender

3.3.1 Spring Manufacturing Process

To form the springs, we first slid enough of the sheet to account for the outermost S bend under the radius of the brake bender (Figure 35). It is better to have more material rather than less since you can always shear off excess at the end. Be sure to keep the edge perfectly parallel with the bender. Because the brake bender cannot do a full 180° bend, wrap a spacer around the bend to preserve it and flatten the edge to 180° (Figure 36).



Figure 35: Sheet metal under brake bender

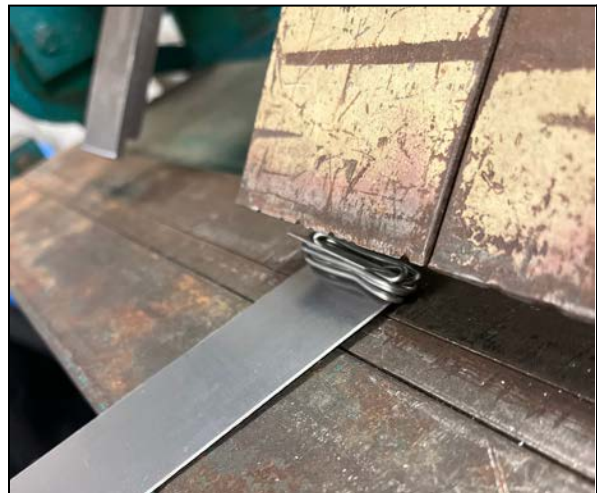

Figure 36: Sheet metal with spacer for second bend

Start the next bend about 0.2 in from the curve, leaving the spacer in. The bend should come out as seen in Figure 37. Repeat the flattening process for the new bend, leaving the spacer in the same place. Start the bend on the flip side exactly 2.95in from the end of the spring as shown below (Figure 38).



Figure 37: Image of second S bend



Figure 38: End of spring 2.95in from the brake bender

Re-insert a spacer into the new bend and flatten the spring again. Do the final bend with the already bent side facing up, as shown in Figure 39, and start it 0.2 in from the previous bend, same as before.



Figure 39: Second S bend with spacer

Note: the straighter you do each bend, the more accurate the finished product will be.

Before unbending, in Figure 40 this is what the spring will look like. Repeat the flattening process one last time, leaving the spacer in, and the final bend on the brake is shown below (Figure 41).

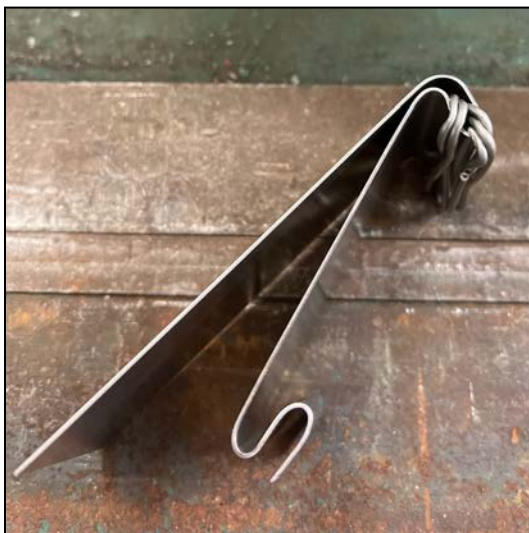

Figure 40: Flat spring with excess material and spacer



Figure 41: Flat spring with excess material unbent

Shear off the excess metal, and bring it over to the tube bender for the final center bend (Figure 42). Line it up like this and accounting for spring-back, bend the center to approximately 26°. The finished product will look like the flat spring in Figure 43.



Figure 42: Flat spring with excess piece sheared off in the tube bender



Figure 43: Flat spring with all bends as designed

3.3.2 Rig Manufacturing Process

The aluminum rig was first modeled in SolidWorks. As seen in Figure 44, the rig has holes on the inside and outside that would be very hard for the Mini Mill to contour out. Therefore, the rig had to be cut into four different pieces for easier milling and assembly purposes.

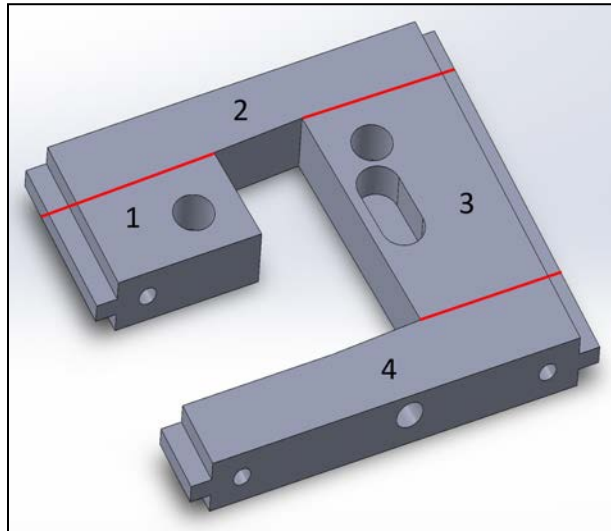

Figure 44: SolidWorks model of rig broken down into four pieces for assembly

To build the aluminum rig, we first used the DoALL Contour Machine to cut out four pieces from the large block of aluminum (Figure 45 & Figure 46). Due to some pieces having cuts angled instead of straight, we needed to face the small piece of the aluminum block to prepare for the CNC Haas Mini Mills. As seen in Figure 47, we used the Manual Mill to get the proper level and measurement of the necessary piece. Once the smaller aluminum pieces were fitted to their proper measurements they were placed in the CNC Haas Mini Mills for machining. We used the CAM features on Fusion 360 to generate CNC code for the HAAS mini mill.



Figure 45: DoALL Contour Machine

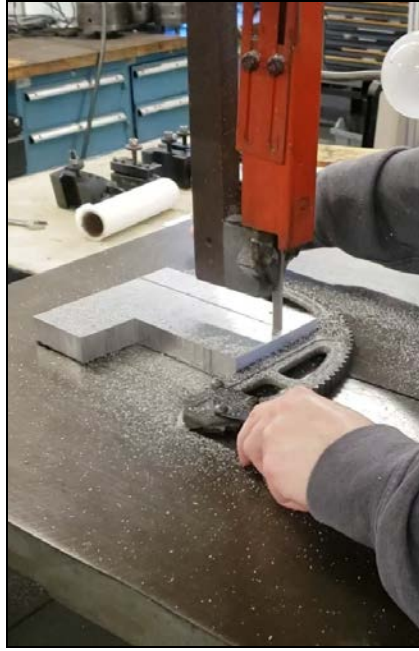

Figure 46: Contouring the block of Aluminum



Figure 47: Manual Mill Machine

The aluminum manufactured blocks were then tapped and drilled to place nails in for assembly. We used #8-32 Phillips flat head stainless steel screws with lengths of 1in and 1.25in. We first used a #29 drill bit to make the holes and then threaded the holes in blocks 1 & 3 using an #8-32 tap found in Washburn Shops. Aluminum blocks 2 & 4 were then cleared using drill bit #16 and then we used an 82° Countersink until the screw tops were flat along the surface. We drilled a hole all the way through block 1 in the area where the pegs of the bridge were placed for key access. Then drilled a 0.5in hole into block 4 where the tension wheel and threaded rod were placed. Another much smaller hole was drilled again next to the 0.5in hole and then carved out using a saw in order to key the hole. The key was inserted to hold the threaded rod in place. Once the finishing touches were done, the blocks were assembled and screwed together (Figure 48).

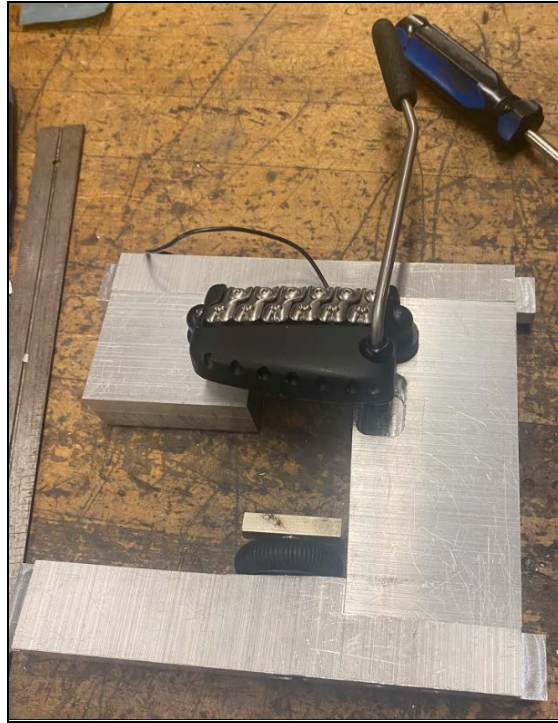

Figure 48: Image of assembled 6061 Aluminum Rig

4.0 Discussion

Our goal for this project was to determine the best method for manufacturing and designing a testing rig and replacement springs for the Fly guitar. The spring is placed between a three-ridge spring plate and a T-bar. The T-bar moves by the tension wheel, allowing players to adjust the tension they need to compensate for the tension of the string gauge and tuning. We explored two types of Fly springs that correspond to two types of string gauge sets: a 9 gauge spring that is used with a 9 gauge string set and a 10 gauge spring that is used with a 10 gauge string. “These flat springs sold by the Parker Fly are a 1095 annealed and tempered steel coated with zinc nickel and trivalent chromate” (Postans, 2021). The 9 gauge spring was manufactured with 0.022” +/- 0.001” annealed spring steel and the 10 gauge spring was made from 0.024” +/- 0.002”. These springs were made with 1095 steel for their wear resistance and spring properties.

To accomplish these project goals, there were three objectives:

1. Reverse engineer the flat spring used in the Parker Fly.
2. Design and manufacture a testing rig to test flat springs.
3. Manufacture a die to produce and form springs.

To reverse engineer the flat spring used in the Parker Fly guitar, we summarized our

methods in three steps: Identify Failure, Design Process, and Manufacture. The reason for this project was to provide a solution to the flat springs that were breaking and supply a method of producing better springs. First, we analyzed the original flat spring to identify the faults of the original spring. Then we conducted background research and understood why the spring might fail. We then designed a process to manufacture the spring that possibly avoids the original manufacturer's error. Lastly, we designed and manufactured a rig to test flat springs in.

When testing simulations of the flat spring designs from the previous team in ANSYS, we had one side of the spring in a fixed position and the other side in a frictionless support. We continued applying a force on one side of the spring and tested for equivalent (von Mises) stress, deformation, normal stress, strain, fatigue. After getting our results from ANSYS we identified the failure points. We also calculated the buckling of the original spring to acquire the critical load value, however these calculations only accounted for force in the x direction. The motion of the three ridge plate does not exert force in this way, therefore we cannot definitively rule this cause of failure in or out. Our attempts to model the most accurate motion in ANSYS proved unsuccessful.

Machines used to understand the original spring properties and failure mechanism included a Buehler Wilson Tukon 1202 Micro-Hardness Tester for hardness testing, a stereo microscope and a scanning electron microscope to examine the fracture surface. We discovered the springs from the original manufacturer were produced harder than the specified parameters, and failed by brittle fracture.

We also wanted to measure the amount of force being applied to the spring using force sensors, however, sensors that both could fit into the cavity of the guitar and could withstand the amount of force necessary, did not exist. Instead, a rig was designed that could get a measurement of displacement for the calculation of the force applied while also providing an actualistic look on how the flat spring works inside of the guitar. It was also made and designed to reduce any damages that might happen to an actual Parker Fly while testing the manufactured springs. This helped clarify how the flat spring moves from the side profile as the space inside the guitar is very small to get a complete grasp of what is occurring.

We were able to design a method of manufacturing and heat treatment of the flat spring for the next team to follow. To manufacture the spring we decided to continue with what was used for the original spring material, annealed 1095 spring steel. The Peck Stow & Wilcox USA hydraulic shearing machine foot pedal were used to shear the annealed 1095 spring steel. The Tennsmith brake bender and tube bender were used to form the springs into their shape. Our recommended heat treatment is to normalize the steel at 850°C with an oil quench followed by a temper between 350°C and 375°C.

To manufacture the rig, 6061 aluminum was used. The rig was cut into 4 parts to make manufacturing simpler and assembled with various length screws. This rig utilized a bridge, a T-bar, a wheel, and a keyed screw all from a Parker Fly. It was designed with the 2.75 degree angle of the cavity in the guitar in mind. It was machined using the CAM features in Fusion 360, which is an Autodesk software platform for CAD, CAM, 3D modeling, CAE, and PCB. The

completed rig will be incorporated as a module in a larger rig to provide a better understanding of the inner workings of the guitar, specifically of the spring's motion and deformation. The manufactured rig also helps with testing and breaking springs, that way we don't have to use the electric guitar, potentially causing irreversible damage to it.

5.0 Conclusion and Recommendations

Many tools and a wide range of equipment were used to reverse engineer the flat spring, thereby leaving us with knowledge and understanding and the next team with more information to work off. Our recommendations are as follows:

1. Investigate manufacturing flat spring designs that differ from the geometry of the original spring and test them in the rig.

During our project, we focused on finding the cause of failure, and reverse engineering of the original spring. We did not design new springs to potentially mitigate that failure or be easier to manufacture. We recommend future teams try as many possible designs to get the optimal spring shape for the right feel for the guitarist and maximum longevity.

2. Refine the manufacturing method of the flat spring and optimize the heat treatment to positively affect the strength and hardness of the spring.

Although this may be very challenging, designing a spring that could fit the constraints of the brake bender would prevent the S bends from getting crushed as that was a problem with the original spring design. The best way to form those S bends would be to use a custom bender that pivots twice around a small radius.

With our projected tempering temperatures, the next team should have a starting place to get springs within the range of hardness recommended by the original manufacturer. We recommend they play around with springs in this hardness range and try out different heat treatments that make the springs harder or softer than the original range given to see if there might be a market for guitarists preferring a softer or harder spring even if they might break more often.

3. Test and analyze new spring designs using the rig and our findings regarding the cause of failure.

When new viable springs are designed and manufactured, the next step should be to test them on the rig. This would allow more data collection for potential cause of failure for any future designs. The rig also allows for the springs to be tested under many conditions, such as

one side of the bridge raised or lowered, the spring being in different ridges of the three ridge plate, and light or heavy use of the whammy bar.

4. Continued research into different base materials and protective coatings should also be investigated.

The spring steel we determined to be most suitable for the project was AISI 1095, however, should the next team want to explore alternative materials, we would suggest hardness testing and heat treating other steels, such as AISI 5160.

6.0 Broader Impacts

Reflecting on the American Society for Mechanical Engineers Code of Ethics, we believe our project upholds the Fundamental Principles. These Principles are as follows:

- I. Using their knowledge and skill for the enhancement of human welfare;
- II. Being honest and impartial, and serving with fidelity their clients (including their employers) and the public; and
- III. Striving to increase the competence and prestige of the engineering profession.

Our project is responding to the demand for springs that have been out of manufacturing for over 20 years. This high demand and low supply has led to unethical sales of springs made by individuals with little experience in metal forming and no guarantee of reliability or even usability. To uphold the first principle, the goal of the continued work on this project is to manufacture a spring that is researched and designed to be of better quality than the original manufacturing of the spring, and to sell them at a more reasonable price than unusable springs are being sold now. To uphold the second principle, we intend to be open with all of our findings regarding the reasons we believe the original springs failed to ensure our consumers trust our process and our outcome as much as we do. To uphold the third principle, we are proud to be a part of a group of engineers helping to bridge the gap between the arts and engineering. We hope our project's broader impacts are a positive contribution to music lovers and engineers alike.

7.0 Bibliography

- AISI 1095 (High-Carbon Steel). (1952). In *Alloy Digest - Data on World Wide Metals and Alloys* (pp. 1–2). ASM International.
- AISI 5160 (High Strength Machinery Steel). (1952). In *Alloy Digest - Data on World Wide Metals and Alloys* (pp. 1–2). ASM International.
- AISI 5160 (High Strength Machinery Steel). (1967). In *Alloy Digest - Data on World Wide Metals and Alloys* (pp. 1–2). ASM International.
- 1095 carbon steel • alpha knife supply - AKS™*. Alpha Knife Supply - AKS™. (n.d.). Retrieved November 3, 2021, from <https://www.alphaknifesupply.com/shop/1095-carbon-steel>.
- Ansys (CES) Granta Edupack | Software for Materials Education*. ANSYS Granta Edupack. (n.d.). Retrieved March 9, 2022, from <https://www.ansys.com/products/materials/granta-edupack>
- Bahrami, Amir & Zhang, Yanhui & Peter Tubby. (2015). Effects of microstructure and hydrogen charging on fatigue performance of duplex and superduplex stainless steels. 10.13140/RG.2.1.1756.6246.
- Bilger, B. (2007, May 7). *Struts and frets*. Struts and FRets . Retrieved November 4, 2021, from <https://www.newyorker.com/magazine/2007/05/14/struts-and-frets>.
- Brinell hardness*. Brinell Hardness - an overview | ScienceDirect Topics. (n.d.). Retrieved December 17, 2021, from <https://www.sciencedirect.com/topics/chemistry/brinell-hardness>
- Callister, W. D., & Rethwisch, D. G. (2014). *Materials science and engineering: An introduction*.
- Electrochemical Products Inc. (n.d.). *Trivalent Passivate/chromate FAQ - epi*. Retrieved November 4, 2021, from <https://www.epi.com/media/1695/trivalent-chromates-faq.pdf>.
- European Springs & Pressings Ltd. (2014, March 25). *Flat springs: Not your typical spring*. European Springs. Retrieved October 30, 2021, from <https://www.europeansprings.com/flat-springs-not-your-typical-spring/>.
- Goode, J. (2017, April 26). *Energy-dispersive detector (eds)*. Geochemical Instrumentation and Analysis. Retrieved November 4, 2021, from

https://serc.carleton.edu/research_education/geochemsheets/eds.html.

Hardness testing basics. NEWAGE Hardness Testers - Rockwell Testers, Brinell Testers, Microhardness Testers, Optical Systems and Hardness Testing Software. (n.d.). Retrieved December 17, 2021, from <https://www.hardnesstesters.com/test-types/hardness-testing-basics>

Irvine Springs. (2021, July 23). *Flat springs: Flat Spring Manufacturer*. Irvine Springs. Retrieved November 29, 2021, from <https://irvinesprings.com/flat-springs/>

Jantz Supply. (n.d.). *5160 hi-carbon steel*. Jantz Supply. Retrieved November 3, 2021, from <https://knifemaking.com/products/5160-high-carbon-steel>.

JB Springs. (2018, January 12). *Tension Springs or Compression Springs*. Retrieved December 1, 2021 from <https://www.jbsprings.co.uk/tension-springs-compression-springs/>.

Manzo, V. J. (n.d.). *Fly Spring*. vjmedia. Retrieved November 3, 2021, from https://vjmedia.wpi.edu/Private:Fly_Spring.

Manzo, V. J. (2020). *Guitar Component Testing Rig*. vjmedia. Retrieved December 18, 2021, from https://vjmedia.wpi.edu/Private:Fly_Spring.

Mechanics of materials: Beam buckling " mechanics of slender structures: Boston University. Mechanics of Slender Structures RSS. (n.d.). Retrieved December 17, 2021, from <https://www.bu.edu/moss/mechanics-of-materials-beam-buckling/>

McMaster-Carr. (n.d.). *Easy-to-Form Wear-Resistant 1095 Spring Steel Sheets*. McMaster-Carr. Retrieved December 13, 2021, from <https://www.mcmaster.com/sheets/material~1095-spring-steel/easy-to-form-wear-resistant-1095-spring-steel-sheets/>

Nakasone, Y., Yoshimoto, S., & Stolarski, T. A. (2007, September 2). *Overview of ansys structure and visual capabilities*. Engineering Analysis with ANSYS Software. Retrieved October 30, 2021, from <https://www.sciencedirect.com/science/article/pii/B9780750668750500326>.

Norton, Robert L. *Machine Design: An Integrated Approach*. Prentice Hall, 2011.

Ohring, M. (2007, September 2). *Mechanical behavior of solids*. Engineering Materials Science. Retrieved March 9, 2022, from <https://www.sciencedirect.com/science/article/pii/B9780125249959500313>

- Postans, Thomas Kyle (2021, March 19). *The Spring Project: Designs and Analyses of Springs for the Parker Fly Guitar*. Retrieved from Worcester Polytechnic Institute.
- Pradeep, S. A., Iyer, R. K., Kazan, H., & Pilla, S. (2016, September 23). *Automotive applications of plastics: Past, present, and future*. Applied Plastics Engineering Handbook (Second Edition). Retrieved October 30, 2021, from <https://www.sciencedirect.com/science/article/pii/B9780323390408000316>.
- Stevenage Spring Co Ltd. (n.d.). *Flat Springs, clips and pressings*. stevenagesprings. Retrieved October 30, 2021, from <https://www.stevenagesprings.com/flat-springs-clips-and-pressings>.
- Swapp, S. (2017, May 26). *Scanning electron microscopy (SEM)*. Scanning Electron Microscopy (SEM). Retrieved November 4, 2021, from https://serc.carleton.edu/research_education/geochemsheets/techniques/SEM.html.
- The Ansys Story | 50 years of innovation*. ANSYS. (n.d.). Retrieved November 4, 2021, from <https://www.ansys.com/company-information/the-ansys-story>.
- The Trustees of Princeton University. (n.d.). *NGLOS324 - Martensite*. Princeton University. Retrieved November 4, 2021, from <https://www.princeton.edu/~maelabs/mae324/glos324/martensite.htm>.
- Heat treatment, Editor(s): W.F. Gale, T.C. Totemeier, Smithells Metals Reference Book (Eighth Edition), Butterworth-Heinemann, 2004, Pages 29-1-29-83, ISBN 9780750675093, <https://doi.org/10.1016/B978-075067509-3/50032-4>.
- Ziemian, Constance & Sharma, Mala & Whaley, Donald. (2012). Effects of flashing and upset sequences on microstructure, hardness, and tensile properties of welded structural steel joints. *Materials & Design*. 33. 175-184. 10.1016/j.matdes.2011.07.026.