

Fret to Fretboard Jig

Gavin Lee

Jig Design

The purpose of the fret to fretboard jig is to ensure that the frets are properly adhered to the fretboard. Since the frets are tangless, they must be glued with epoxy to the fretboard, and pressure must be applied evenly throughout the board so that all the frets will stay once the epoxy has finished curing. The jig designed is meant to facilitate this process and is based on the design shown in the video on the vjwiki website. It consists of a bottom half and top half; the bottom half is meant to hold the frets and fretboard while the top half is meant to press down on the board. Figure 1 shows the assembled jig.

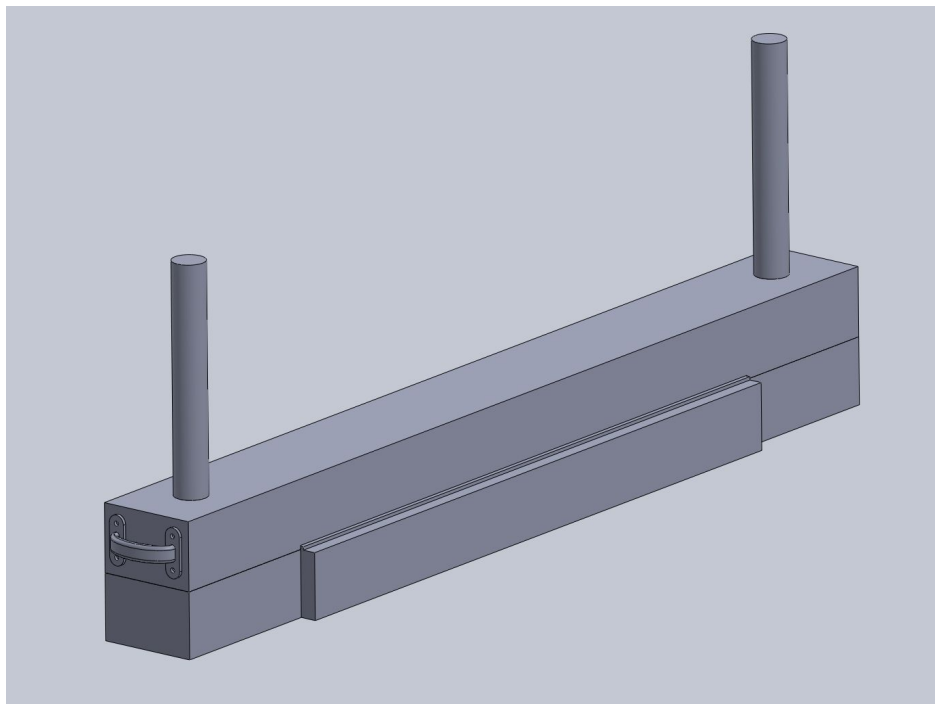

Figure 1 - Fully Assembled Fret to Fretboard Jig

The bottom half of the jig is designed for use with oversized frets; the frets can be trimmed after they are adhered to the board. The two rods on either side of the bottom half are meant to act as both handles and pegs for the top half of the jig to slot through. The section between the two rods on the jig has grooves at the proper distance for a fretboard with twenty four 6105 frets, and the whole section is indented by the radius of the fretboard. There are also two slight overhangs on either side of this section of the jig to help keep the frets in place. The bottom half of the jig is depicted in Figure 2. The top half of the jig simply has two handles on either side, two holes to slot through the rods on the bottom half of the jig, and a bottom contoured to the radius of the fretboard.

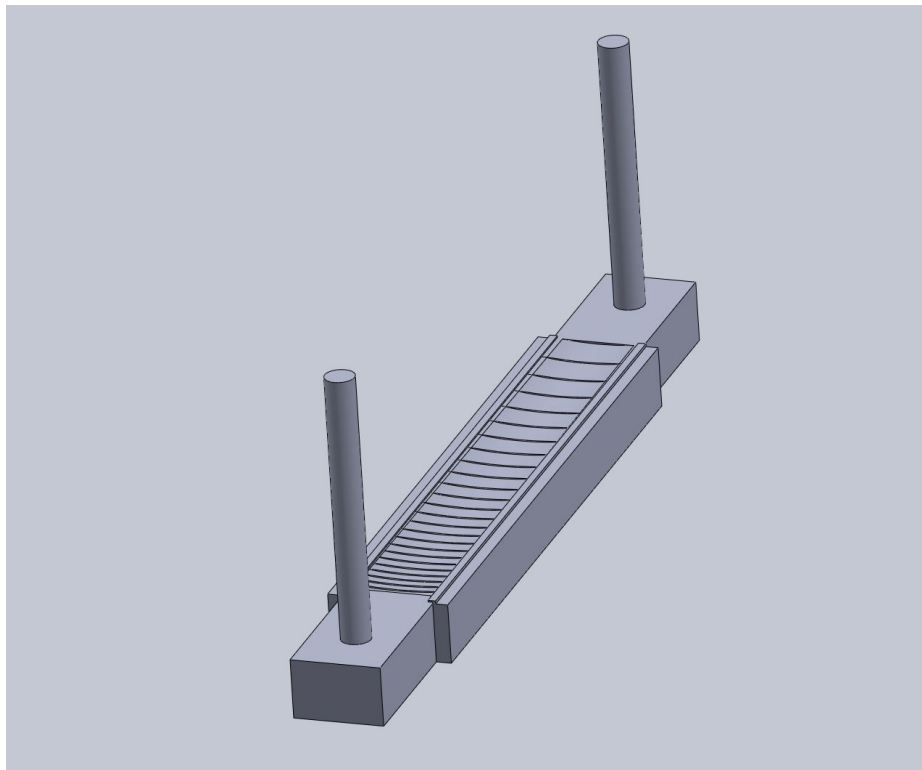

Figure 2 - Bottom Half of the Fret to Fretboard Jig

Modifications can be made to the jig to improve the design as well. Currently, the rounded part of the top half of the jig could be smoothed better than it currently is, as at present it is fairly jagged. Additionally, the two side parts with the overhang depicted in Figure 2 can be modified to be removable to allow for easier removal of the fretboard when it's done being glued. This could work in tandem with a modification made to the section where the frets are placed. Instead of only being able to work with a single number and size of fret, the middle section could be made into a slot system where different plates could slot into the jig. These plates would have grooves for different sizes and number of frets.

Jig Workflow

Once the frets have been cut, sanded, and bent to the proper radius, they may be slotted into the grooves in the bottom half of the jig with their bottom side facing up. Epoxy is then added to the bottoms of the frets while activator is added to the slots in the fretboard, which has already been radiused with fret slots cut into it. The fretboard is then flipped upside down and placed onto the bottom half of the jig so that the fret slots of the board are pressing into the frets. The top half of the board is then placed over the bottom half, slotting through the rods. Clamps are then used to keep the two halves of the jig pressed together while the glue sets. Once the glue has set, the clamps and top half of the jig can be removed, and the fretboard can be removed.

Addendum Fret-to-fretboard Jig Report (May 2020)

Question from Prof. Manzo:

In the "fret to fretboard jig" report, you said: "Modifications can be made to the jig to improve the design as well. Currently, the rounded part of the top half of the jig could be smoothed better than it currently is, as at present it is fairly jagged. Additionally, the two side parts with the overhang depicted in Figure 2 can be modified to be removable to allow for easier removal of the fretboard when it's done being glued. This could work in tandem with a modification made to the section where the frets are placed. Instead of only being able to work with a single number and size of fret, the middle section could be made into a slot system where different plates could slot into the jig. These plates would have grooves for different sizes and number of frets."

I have a few questions: this is designed to accommodate 6105 frets, so 1) do you mean specifically frets that are 095" X .047" and 2) are those the dimensions of the frets on the fretboard you have?

My understanding after reading this paragraph is that this jig, as it is, is not ready/worthwhile to be machined and then used until these modifications are made; is that correct? It's not clear to me what all of the implications are with regard to the need for modifications to current design. Do you agree that, given the cost of stock materials and the time needed to machine this jig, 1) the need for better smoothing, and 2) the lack of a slot system for plates that accommodate frets of different dimensions are compelling reasons to defer fabricating this jig until these modifications are integrated into this design?

Response from Team:

As a brief response to your initial questions regarding the fret to fretboard jig: yes, specifically 095" x .047" frets, and yes those are the current dimensions implemented in the design.

As far as whether it is worthwhile to machine the jig as is or wait until modifications are made, that depends on the kinds of fretboards you ultimately wish to make, though I would say the smoothing aspect should be handled before machining the jig. The bottom half of the jig is fine, but it's the top half that has the jagged curve. I'm not sure entirely why that's the case, and there's probably a better way to handle the changing radius of the fretboard than what I did, but regardless the radius of that portion of the jig currently isn't sufficiently smooth (for reference, this was my first time using Solidworks in 4 years). As far as modifying the jig to accommodate different fret sizes, I included that portion to address one of the stretch objectives

initially listed on the wiki for adhering frets to the fretboard (from what I recall it said something about perhaps being able to use 6150 frets in addition to 6105 frets). What I had envisioned was those two side portions of the bottom half of the jig being detachable in some way, such as being held in place with screws when in use. If you wished to use the jig with a different fret size, you would undo the screws and remove those two pieces. The middle section, instead of being a solid block with a section shaped to hold frets of a certain size and a fretboard of a certain radius, could instead be a slot system where you'd slide in a plate that would hold frets of the desired size. Looking at what the fretboard to neck group has done, you could potentially modify the plate they use for their jig (the one that the neck and fretboard directly rest on) and use that as a base for devising plates that accommodate different sized frets.

So to summarize, the top half of the jig should be further refined before any machining takes place. Beyond that, if you only wish to make fretboards with 6105 frets, then the jig will be ready to be tested. If, however, you do wish to be able to make fretboards with different sizes of frets, then I would recommend making the modifications I have suggested (or something of similar effect, I'm sure whoever picks this up will have ideas I never thought of to achieve the same goal) before moving on with machining.

I hope this answers your questions; if you have any further questions regarding this part of the project feel free to reach out to me.

Followup Question by Prof. Manzo:

In your opinion, would a silicone rubber piece on the underside of the top part help remedy the design and provide more forgiveness for an uneven arc? Would the model still need to be "smoothed" with the addition of such a rubber piece, and, if so, would the rubber piece need to have an arc or grooves/compensation for frets?

Response from Team:

A rubber piece could help; it wouldn't need grooves for the frets as it would be applied to the backside of the fretboard, but it would need an arc to help account for the radius of the fretboard, as the fretboard would have been radiused by this point. The model at that point wouldn't necessarily even need the portion with the uneven arc if you made the rubber piece with a flat back, and changing the model that way would be simple as you'd just delete that feature. Thinking about this now, if you wanted to make the jig even more modular than what I've suggested, you could have different rubber pieces with different arcs to account for fretboards with different radiuses. If you do choose to keep the uneven part of the model, then I would still suggest trying to smooth that feature further, even with the rubber piece, as it is very uneven right now and I don't think it would cause pressure to be distributed evenly.

Information Citation:

1. https://vjmedia.wpi.edu/Private:Fly_Clone#Fret-to-Fretboard_Jig_.5BIN-DEVELOPME
[NT.5D](#)