

www.fishman.com

FISHMAN[®]

**USER GUIDE
AURA[®] SIXTEEN**

Welcome

Thank you for making Fishman a part of your acoustic experience. We are proud to offer you the finest acoustic amplification products available; high-quality professional-grade tools to empower you to sound your very best. We are confident Aura Sixteen will both enhance and inspire your music making.

Quick Start

Power – Install a 9V alkaline or lithium battery (not included).

Set the controls – **Volume** at minimum, **select** at #1 and **blend** at its mid-point.

Plug in – Use standard ¼-inch shielded instrument cables. Place any other pedals after Aura Sixteen.

Set trim – Play hard and adjust input **trim** (right side) so **clip/batt** LED flashes occasionally.

Select an Image – Raise the **volume** and audition the 16 Images with the **select** knob. Since Aura Sixteen ships with dreadnought Images, it's important to use a dreadnought style guitar or see page 12 on downloading Images for your instrument.

Blend to taste – turn left for more pickup and right for more Image.

Kill feedback – If feedback starts, change the position of the **phase** switch.

Bypass – Step on the foot switch to alternate between blended Image sound and dry pickup (this is the default setting).

Mute – To alternate between blended Image sound and mute, hold the foot switch down until the LED flashes. Repeat to return to bypass.

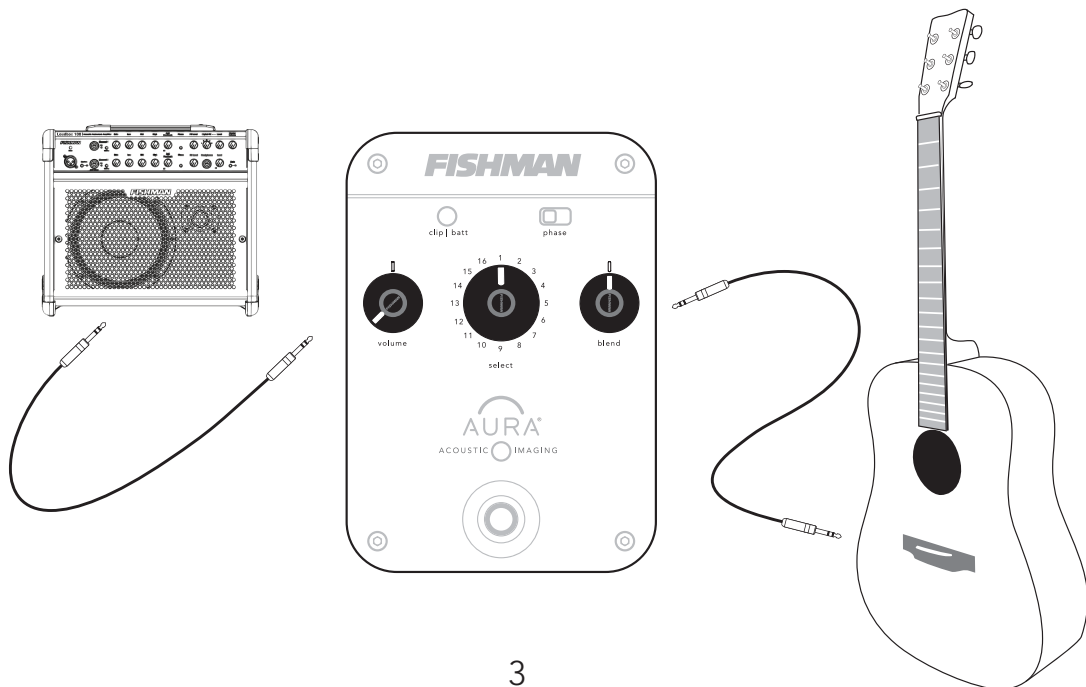

What is Aura?

Aura Acoustic Imaging Technology uses digital algorithms developed in Fishman's audio laboratories to restore a studio-miked sound to an acoustic instrument. To achieve this, we record instruments using world-class microphones and techniques to capture an "Image" of the natural sound that your acoustic instrument emits when miked in a professional studio. This Image, when recorded direct or played through an amp, mixer or PA, blends with your instrument's pickup to produce an incredibly accurate recreation of the original recording.

Aura Acoustic Imaging processors sound best when used with Fishman undersaddle pickups and magnetic soundhole pickups. When we record each instrument, we use our Acoustic Matrix undersaddle pickup. So, when you play through an Aura processor, you'll get the best results using our Acoustic Matrix pickup. We do not recommend soundboard-mounted pickups, bridge-plate pickups, multi-sensor pickups or microphones for Aura products since they include unnecessary resonances that can interfere with the Aura processing.

Choosing an Image

To get the most realistic tone from Aura Acoustic Imaging, you should **always match your Images with the instrument type** you're playing. For example, choose dreadnought Images when plugging in a dreadnought body style guitar; choose mandolin Images if you're playing a mandolin. Don't hope to derive a mandolin sound from a dreadnought or try to turn your orchestra body style guitar into a 12-string. If you are not sure which body type your guitar falls into, we suggest you audition several Images from using the search tools in the Aura Image Gallery and let your ears decide. See page 12 for details on Downloading Images.

Aura Custom Shop

For the ultimate in Aura Imaging, be sure to check out the Aura Custom Shop at fishman.com. For a modest fee, you send us your instrument and we'll create a set of Images using our best microphones, custom recorded for you.

Aura Image Gallery

The Aura Image Gallery software manages a vast library of Images created from an ever-expanding list of instruments, and provides tools to search and store sets of Images. Browse the Image Library to find your instrument, then drag and drop an Image into an Image Set for download into Aura Sixteen.

Making Connections

Playing live

For the best sound reproduction when performing live, connect your Aura Sixteen to an acoustic instrument amp, PA system, powered monitor or other full-range system.

Going direct

For direct recording, there is no better solution than using Aura Sixteen. In fact, an acoustic track recorded with just a pickup can be re-recorded using Aura to restore the miked sound.

About the Images

Dreadnought

Aura Sixteen comes pre-loaded with 16 Images recorded using the most popular dreadnought guitars.

Be sure to check out the section on Downloading Images (pg. 12) from the Aura Image Gallery if you're not playing a dreadnought style guitar.

Image #	Top Wood	Back and Sides	Microphone Type
1	Spruce	Rosewood	DPA® 4011
2	Spruce	Mahogany	Soundelux® E47
3	Spruce	Rosewood	Soundelux® E47
4	Spruce	Rosewood	Neumann® KM84
5	Spruce	Rosewood	Schoeps® CMC64
6	Spruce	Rosewood	Schoeps® CMC64
7	Spruce	Rosewood	Shure® KSM141
8	Spruce	Rosewood	Neumann® M147
9	Spruce	Rosewood	Neumann® M147
10	Spruce	Rosewood	Schoeps® CMC64
11	Spruce	Mahogany	AKG® C414
12	Spruce	Rosewood	Neumann® U87
13	Spruce	Rosewood	Neumann® U87
14	Composite	Composite	DPA® 4011
15	Spruce	Rosewood	Neumann® M147
16	Spruce	Mahogany	Shure® SM57

Fishman Transducers, Inc. is not affiliated with any of the forementioned companies or their respective trademarks, registered trademarks, product models or copyrights.

Using effects

When using your Aura Sixteen with other effects devices, place the Aura Sixteen first in the chain after your guitar.

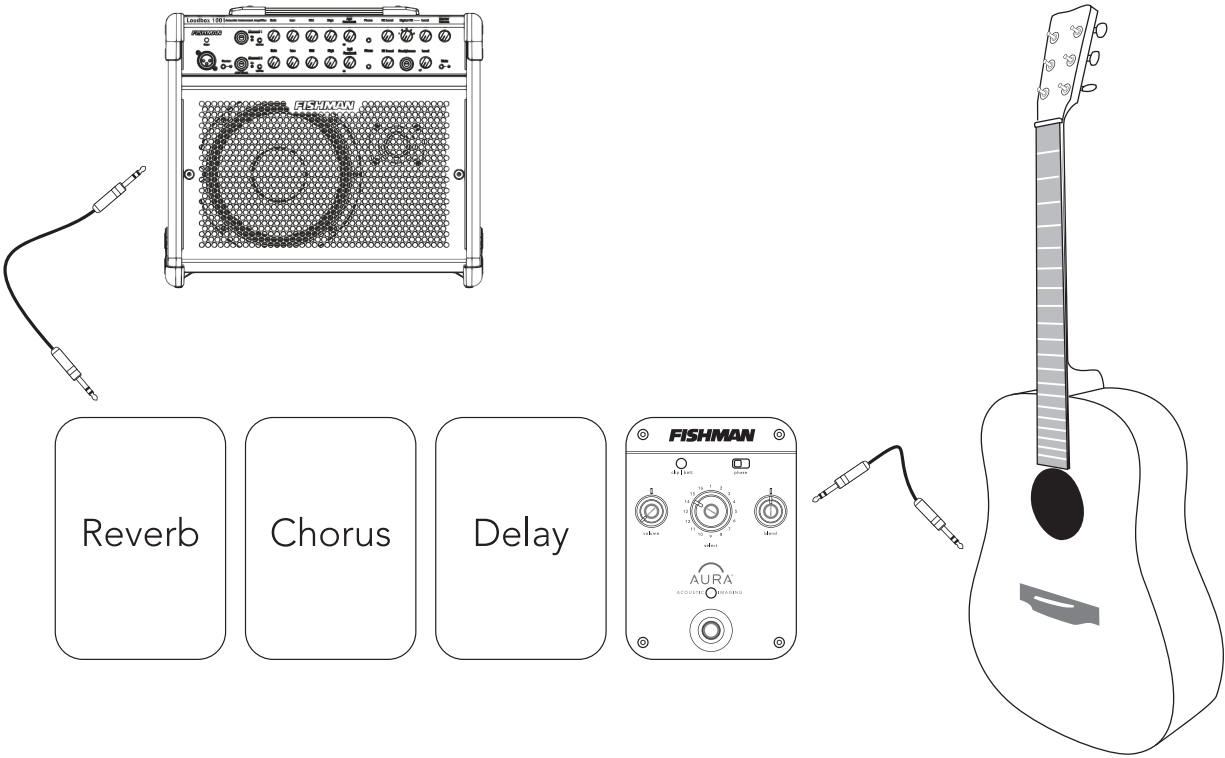

Left Side Panel

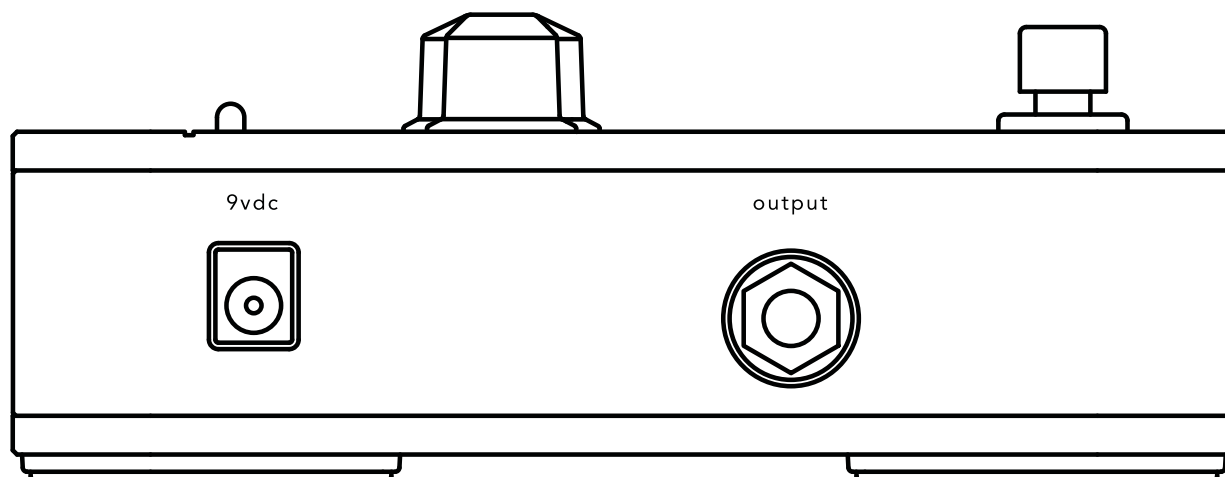

Output

Use a standard ¼-inch instrument cable to connect the **output** to your amplifier, mixer or effects devices. You can also connect this **output** to an unbalanced input on a recording system.

9VDC

Power may be supplied by either a 9V battery (battery compartment underneath the pedal) or the Fishman 910-R (for 110V). Insert a plug into the **input** jack, and Aura Sixteen powers up. To conserve the battery, remove the plug from the **input** when not in use.

The **clip/batt** indicator will light steadily when it is time to change the battery. When the **clip/batt** LED comes on you have approximately one hour of remaining battery life.

For AC power, use the Fishman 910-R (for 110V) or other suitable 9V adapter (see Specifications).

Right Side Panel

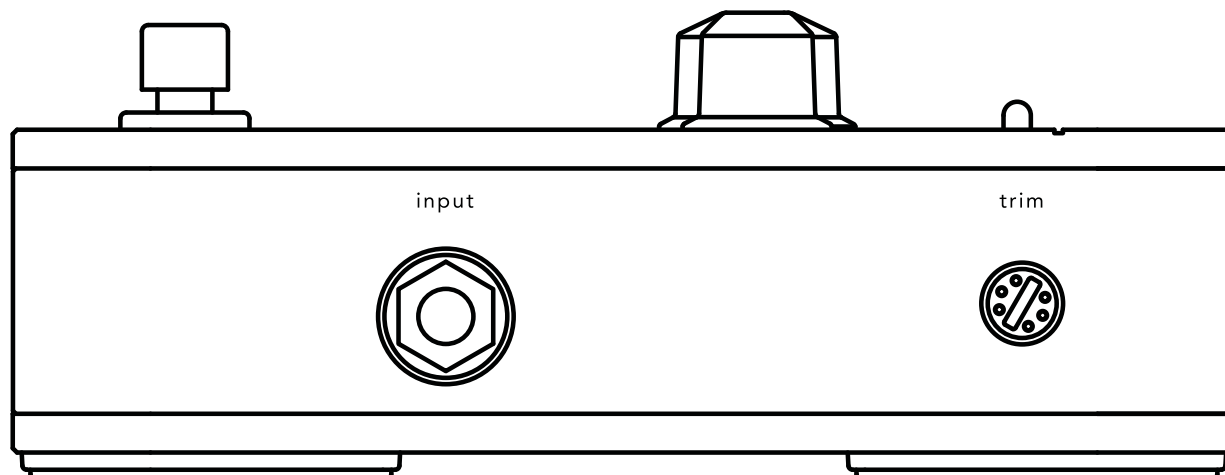

Input

Plug in your instrument here with a standard ¼-inch instrument cable. If you have a passive undersaddle pickup (no battery onboard), always plug into Aura Sixteen first, even if you use a pedal tuner.

Insert a plug into the **input** jack, and Aura Sixteen powers up. To conserve the battery, remove the plug from the **input** when not in use.

Trim

Raise or lower the **trim** to optimize the input level for your pickup. Play hard and adjust **trim** so **clip/batt** flashes occasionally. Some pickup systems may not cause the light to flash at all and other onboard preamps may require you to turn their output down to achieve an optimum level.

Controls

Volume

For the cleanest signal, set the **volume** as high as possible without clipping the next device in the signal chain. If you hear distortion and the **clip/batt** light is not flashing, reduce the **volume**.

Select

The 16 Images you can choose with the **select** knob are hand picked for a dreadnought body style guitar. Try all 16 and pick the ones that compliment your playing style and sound good in the room. For example, dark/deep sounding Images may add impact to a solo performance. Brighter/lighter Images may compliment an ensemble. There are no rules; try them all and decide which works best for you.

Blend

Position the **blend** knob straight-up at 12 o'clock and you'll hear a 50/50 mix of Image and pickup. Turn the **blend** all the way right for just Image; all the way left for just pickup. Most performers blend in some pickup with the Image for clarity and definition.

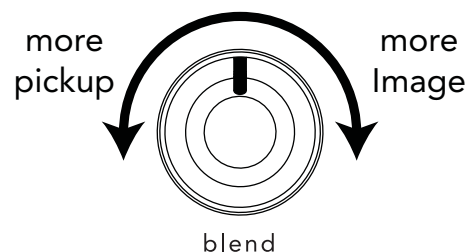

Suggestions

- For live performance try backing off the Image by setting **blend** to about 10 or 11 o'clock or about 65% pickup. You won't need too much Image blended in to achieve a great live sound. If feedback occurs, flip the **phase** switch.
- For recording, try blending in more Image for a realistic acoustic sound. Set the **blend** to taste. Again, you'll often get good results with a little bit of pickup blended in with the Image for clarity and definition.

Controls (continued)

Phase switch

Use the **phase** switch to improve bass response at low volume or to control feedback at high volume. Play your guitar and toggle the **phase** switch back and forth until you achieve the desired result.

Foot switch

Step on the foot switch to bypass the Aura effect. When you stomp, you'll hear the dramatic difference between the Image blend and the dry pickup. When the light above the footswitch is on, the Image is active. Note when the effect is bypassed, your guitar signal remains buffered. Also, if the **blend** knob is set to 7 o'clock, you will hear no difference between active and bypass states.

Mute (optional mode)

You may set up the foot switch to alternate between the Image blend and muted output. To enable the mute option, hold the foot switch down until the LED flashes. Repeat to return to bypass.

Downloading Images

The Aura Image Gallery software manages a vast library of Images created from an ever-expanding list of instruments, and provides tools to search and store sets of Images.

If you can't find your exact instrument in the list, use the built-in Image Wizard to find the closest match. For example, if one of our hundreds of Images doesn't match your instrument exactly, you can still find a great sounding Image by matching similar tone woods and body styles. Experiment with these tools, and use your ears to determine what sounds best for your playing or musical style.

To access this library of additional instrument Images, install the Aura Image Gallery on your computer. Then, gently remove the USB cover from the right side of the unit and connect the included USB cable to the side of the preamp and your computer. Create a new Image Set and load your Images into Aura Sixteen

Be sure to install the Aura Image Gallery software prior to connecting Aura Sixteen for the first time.

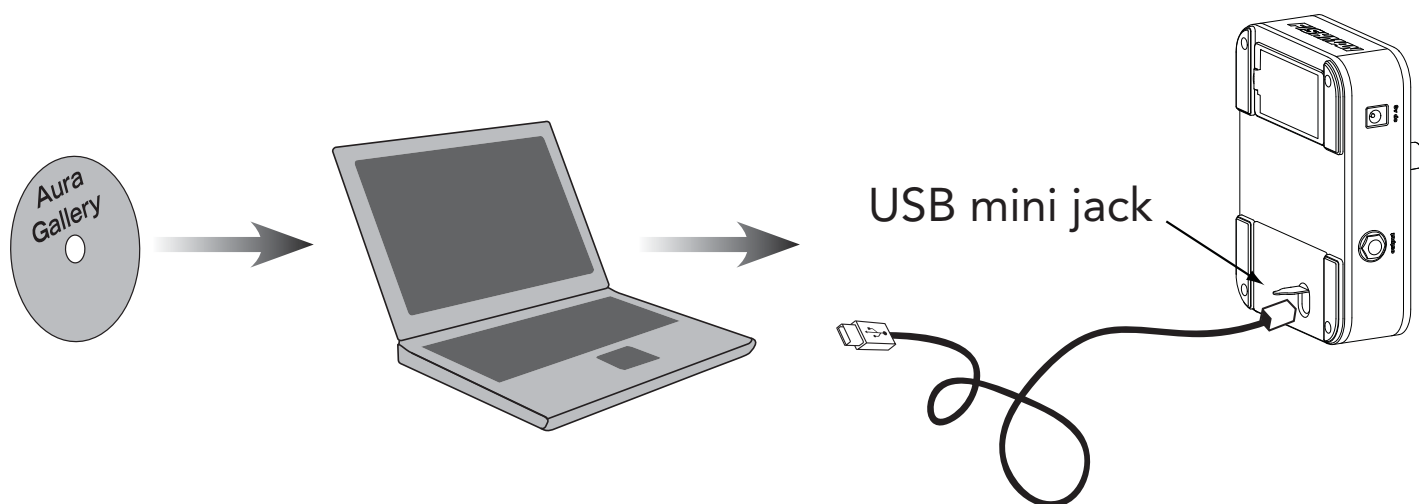

Specifications

Input impedance:	10M Ohm
Input trim gain range:	-10dB to +2dB
Nominal Output impedance:	3.5k Ohm
Max. Output level (onset of clipping):	+2.4dBV
Digital signal path:	
A/D, D/A conversion:	24-bit
Signal processing:	32-bit
Baseline noise:	-92dBV (A-weighted)
Dynamic range:	94dB (A-weighted)
Power supply:	9V battery or 9VDC adapter
Typical in-use current consumption:	18mA
Typical 9V battery life:	27 hours using alkaline battery 54 hours using lithium battery)
9V adapter (optional):	Fishman 910-R (for 110V) or suitable filtered & regulated, 200mA type, tip = negative 5.5mm O.D., 2mm I.D.
Phase switch:	Left position = non-inverting

All specifications subject to change without notice

FISHMAN
www.fishman.com